

***APPENDIX-B***  
***Construction Safety Manual***  
***on***  
***HEALTH, SAFETY AND ENVIRONMENT (HSE)***

## TABLE OF CONTENTS

---

<u>Sl.No.</u>	<u>Details</u>
---------------	----------------

**A. HEALTH SAFETY AND ENVIRONMENTAL POLICY**

**B. SCOPE OF SAFETY**

**C. 4 M CONCEPT (SYSTEM)**

1. Work at Height
2. Electrical Safety
3. Excavation, Trenching & Shoring
4. Hot Work operation
5. Traffic Management
6. Hand tool & Power tools
7. Material Handling and Construction Equipment Safety
8. Fire safety
9. Confined space
10. Demolition of building & Structure
11. Lock Out & Tag Out (LOTO)
12. Environment
13. Health & Hygienic
14. PPEs
15. First Aid
16. Construction Health & Safety Regulations, codes & best practices
17. Check sheets

## **HSE POLICY:**

**Every contractor should prepare a written statement of policy in respect of environment, safety and health of construction/building workers and submit the same for the approval of the competent authority (As per Safety Standards).** The intention and commitment should be taken into account in making decisions relating to plant, machinery, equipment, materials and placement of construction / building workers. The contractor should revise the policy as often as necessary.

A copy of the policy should be displayed at conspicuous places in local Language, English and the language understood by the majority of building workers at the construction site.

## **SCOPE:**

This document establishes the minimum Health, Safety and Environment requirements for work to be performed by Contractors or Service Providers at SITE.

The requirements prescribed in this specification are to protect SITE and Contractor's personnel against hazards arising in connection with work, and to prevent accidental damage to property or to the environment.

Contractor need to comply with all applicable statutory regulations related to health, safety and environment, construction and contractual work.

# 4 M SYSTEMS

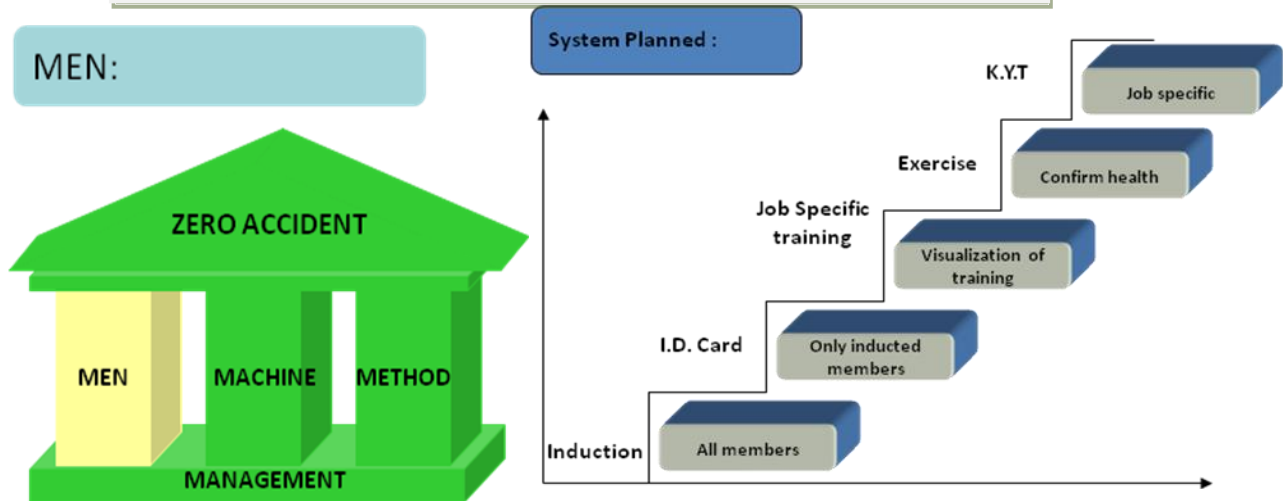

CONTRACTOR IDENTITY CARD						
(Affix Stamp Size Photograph)	Name :					
	Contractor's Name :					
	Issue Date :					
	Age :					
	Blood Group :					
Aug-14	Authorized Sign :					
	General Safety	Height Work	Hot Work	Electrical Work		



## Challenges :

75% of Accident caused by Unsafe action

1. Floating population

2. Literacy level low

3. Multi Language members

4. Lack of Knowledge

5. Physical condition

## Level up awareness through

- \* Educate rule & standard
- \* Share Do's & Don'ts
- \* Importance of safety
- \* Experience the necessity safety

**MACHINE:**

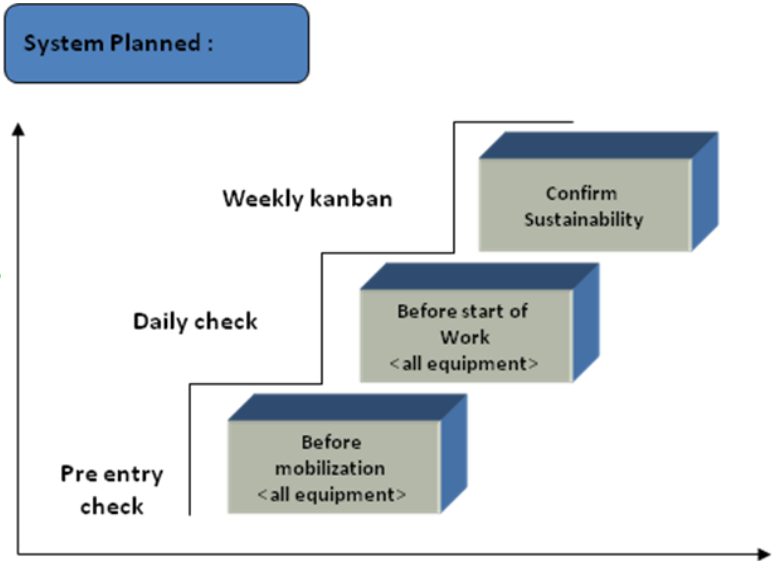
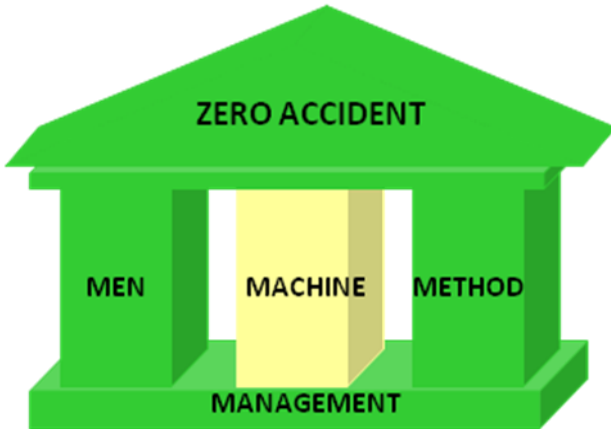

**Challenges :**

23 % accident  
Unsafe condition



1.Hired machines

2.Low std machines

3.Dynamic environment

4.Poor maintenance

**Safe equipment safe work**

- \* Share Standard for all
- \* Self confirmation
- \* Early detection of abnormality



METHOD:

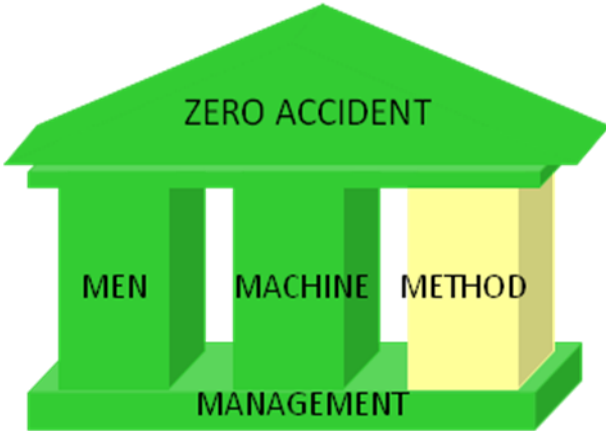

System Planned :

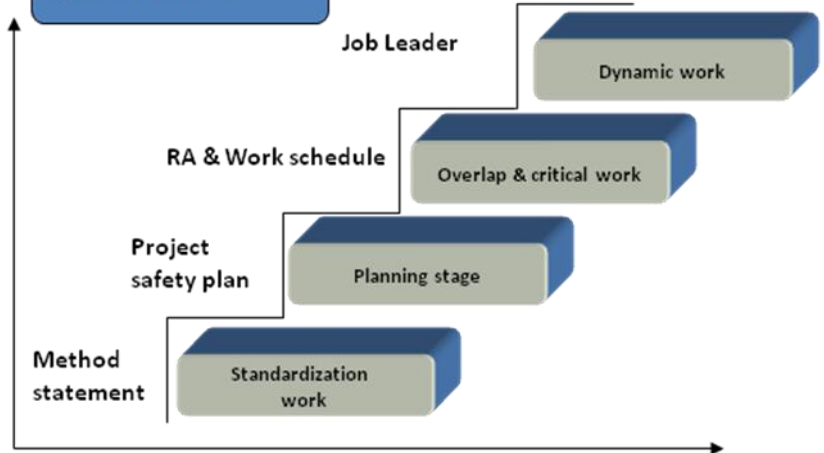

Sl. No.	Activity	Job description	Method statement	RA & Work schedule	Standardization work
1	Site preparation	Site preparation activities including clearing, leveling, and site layout.	Method statement for site preparation, detailing safety measures for excavation and heavy machinery use.	RA & Work schedule for site preparation, showing task sequence and resource allocation.	Standardization work for site preparation, including safety protocols and equipment use.
2	Foundation work	Foundation work including excavation, formwork, and concrete pouring.	Method statement for foundation work, detailing safety measures for excavation and concrete handling.	RA & Work schedule for foundation work, showing task sequence and resource allocation.	Standardization work for foundation work, including safety protocols and equipment use.
3	Structural work	Structural work including steel erection, concrete casting, and formwork.	Method statement for structural work, detailing safety measures for steel erection and concrete handling.	RA & Work schedule for structural work, showing task sequence and resource allocation.	Standardization work for structural work, including safety protocols and equipment use.
4	Roofing work	Roofing work including steel erection, concrete casting, and formwork.	Method statement for roofing work, detailing safety measures for steel erection and concrete handling.	RA & Work schedule for roofing work, showing task sequence and resource allocation.	Standardization work for roofing work, including safety protocols and equipment use.
5	Finishing work	Finishing work including painting, plastering, and final site cleanup.	Method statement for finishing work, detailing safety measures for painting and site cleanup.	RA & Work schedule for finishing work, showing task sequence and resource allocation.	Standardization work for finishing work, including safety protocols and equipment use.

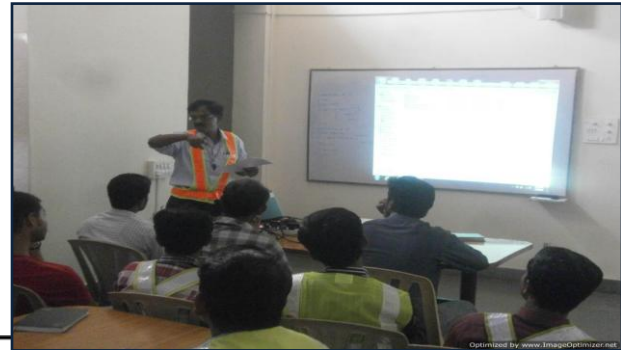
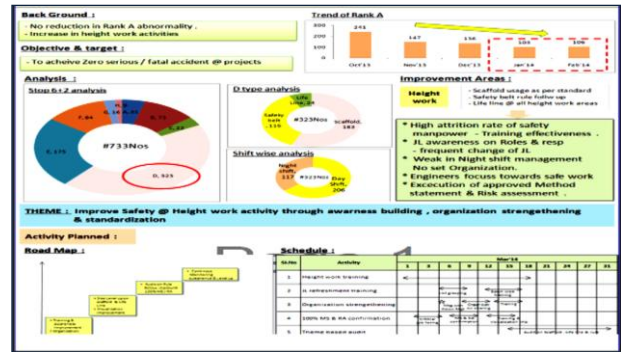

Challenges :

23 % accident  
Unsafe condition

1.No standardization of work

2.No risk management in Planning stage

3.Overlapping of works

4.Dynamic environment

**Eliminate Rank A risk first**

\* Standardization of work in planning stage

\* Reduction of risk

\* Manage multiple activity

\* Critical activity control

# MANAGEMENT:

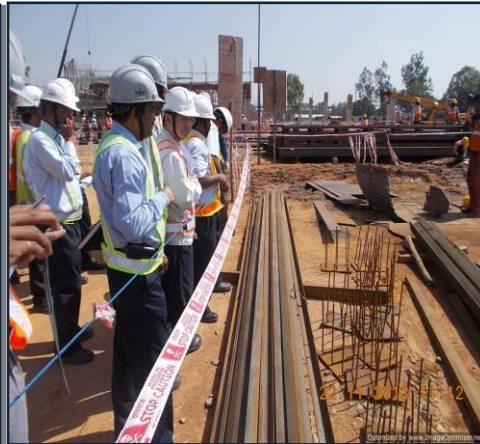
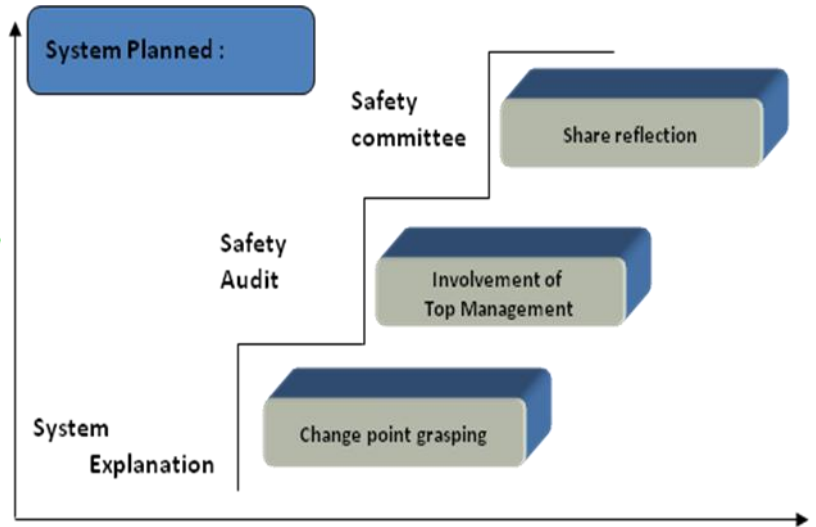
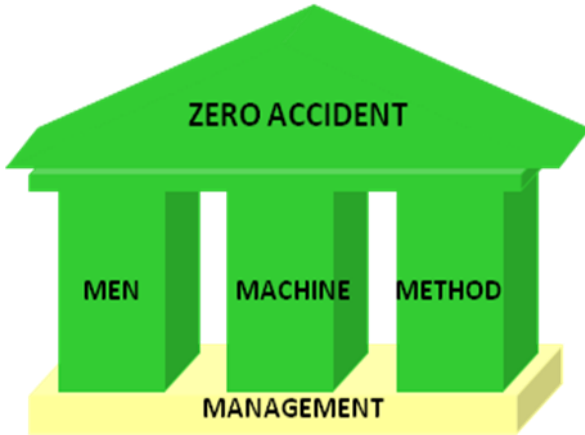

## Challenges :

Poor management  
Lead to  
System collapse

1. Lack of management involvement

2. Lack of initiation for level up

3. Lack of share reflection

4. Difficult to grasp change point

## Safety is management itself

\* Involve contractor & top management

\* Establish platform for sharing reflection

\* Easy for judge change point

## **SAFETY & HEALTH EXPECTATIONS / REQUIREMENTS**

### **Basic Safety expectations / requirements.**

- The Contractor shall assume full and independent responsibility for the safety and health of its employees when working at SITE and also agrees to perform in full compliance with all applicable laws and Indian standards and requirements.
- The Contractor shall not expose SITE employees to any unsafe acts or conditions which can be reasonably predicted as hazardous or unsafe or which otherwise violate statutory provisions and SITE safety procedures.
- Contractors shall perform documented self-inspection(s) of their work operations, facilities and equipment at least once per day for construction projects. Written records shall be maintained of all safety and health inspections made by the Contractors and submit the findings and closure reports to SITE on daily basis.
- Contractors shall be required to attend a project specific / job orientation meeting organized by the SITE Project coordinator (person who hires the services) for the purpose of becoming familiar with this requirement.
- The Contractor's employees assigned to work at SITE will attend an HSE orientation prior to the start of the work, at which environment, safety and health requirements and rules will be discussed. This induction shall be coordinated by the SITE Project Coordinator and conducted by the HSE Team.
- A Contractor who hires subcontractors, the hiring Contractor shall be responsible for communicating all requirements contained in these documents to the subcontractor.
- Contractors shall inform the SITE Project Coordinator as soon as possible, not to exceed twenty-four hours, of any accidents that occur at SITE involving contractors operations and shall participate in any SITE led investigations of that accident.
- Contractors shall ensure, to SITE's satisfaction, that their employees assigned to SITE are physically able to safely perform their assigned tasks.



# 1. WORK AT HEIGHT

## 1.1 Fall Protection Requirement

History of accident reveals that maximum fatalities at construction site are due to falls from height.

Considering high risk associated with the activities,

SITE has serious expectations from the contractor for 100% compliance for zero accident at construction site.

Falls may result from a number of factors, including unstable working platforms, inadequate engineering controls like guardrails, non-standard ladders, etc., and improper use of fall protection equipment.

At SITE, all activities involving working above 6 feet height are covered under the fall protection requirement in case of construction project. In case of non-construction project, 4 feet height is considered for fall protection.

Following steps must be followed for all high-risk activities while working at height:

- Make fall protection part of your workplace safety and health program
- Identify/recognize and evaluate fall hazards before allowing worker to work
- Eliminate fall hazards, if possible.
- Train workers to recognize fall hazards.
- Proper use of appropriate equipment like scaffolds or elevated working platform with guardrail, ladder etc to prevent falls and to protect workers by encouraging use of approved safety harness with double lanyards, safety net system, etc.
- Inspect and maintain fall-protection equipment before and after using it.

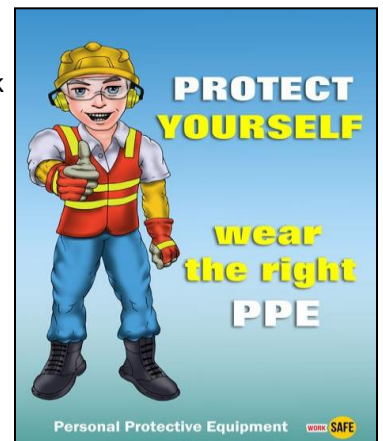

## 1.2 Personal Fall Protection Systems

### a) Full body harness and personal fall arrest system

- All persons working at height of 6 feet or more should wear safety harness and lifeline should be anchored properly. Anchorages used to attach personal fall arrest systems shall be independent of any anchorage being used to support or suspend platforms and must be capable of supporting at least 5,000 pounds (22.2 kilo Newton) per person attached. Lanyards and vertical lifelines must have a minimum breaking strength of 5,000 pounds (22.2 kilo Newton).
- These consist of an anchorage, lifeline, and a full body harness and may include a deceleration device, or suitable combinations.
- While working at height where there is possibility of freefall person should use fall arrest system. If a personal fall arrest system is used for fall protection, it must do the following:
  1. Limit maximum arresting force on an employee to 900 pounds (4 kilo Newton) when used with a safety belt and limit maximum arresting force on an employee to 1,800 pounds (8 kilo Newton) when used with a body harness;
  2. Be rigged so that an employee can neither free fall more than 6 feet (1.8 meters) nor contact any lower level;
  3. Bring an employee to a complete stop and limit maximum deceleration distance an employee travels to 3.5 feet (1.07 meters); and
  4. Have sufficient strength to withstand twice the potential impact energy of an employee free fall at a distance of 6 feet (1.8 meters) or the free fall distance permitted by the system, whichever is less.

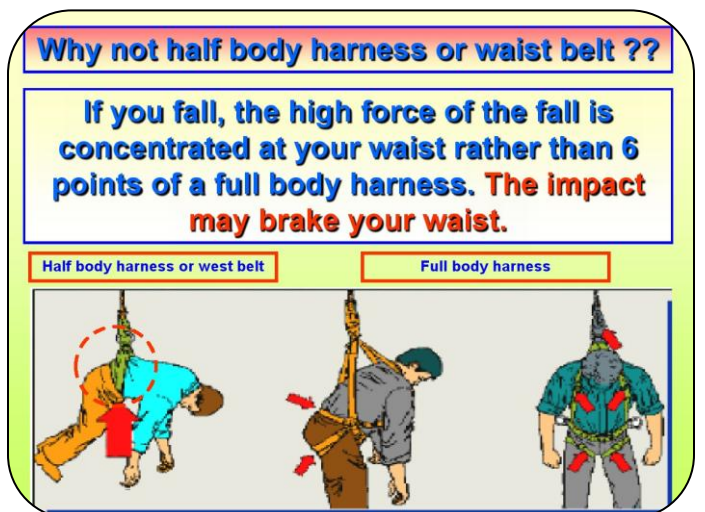
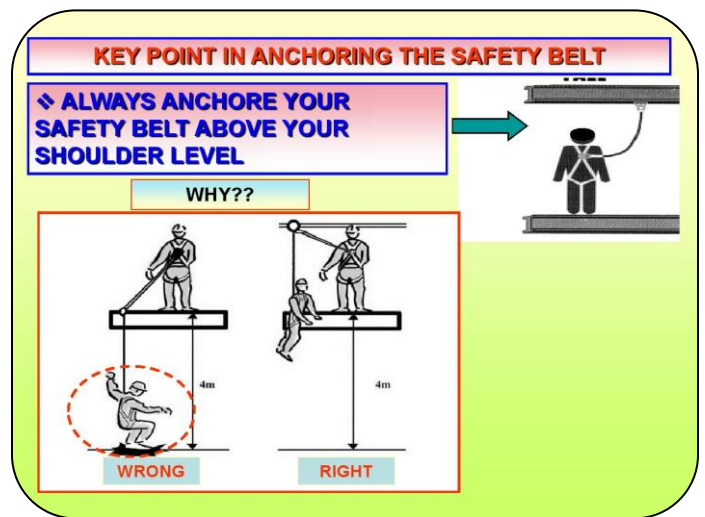
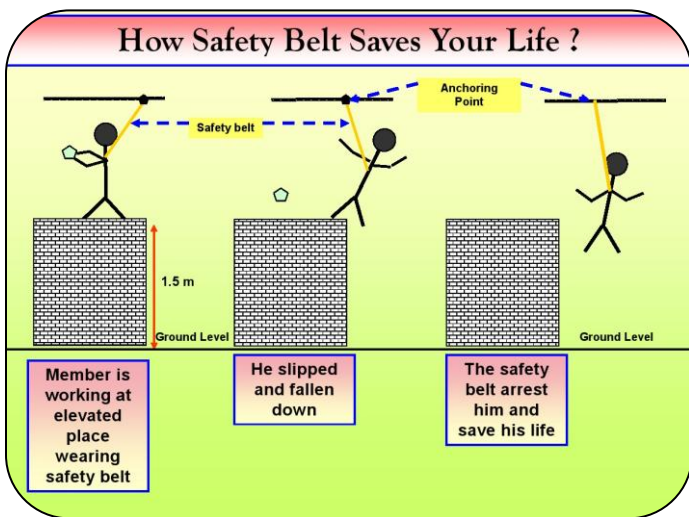

### 1.3 Safety Net Systems:

- Safety nets should be installed as close as practicable under the walking/working surface on which employees are working and never more than 30 feet (9.1 meters) below such levels.
- Defective nets shall not be used. Safety nets shall be inspected at least once a week for wear, damage, and other deterioration.
- The maximum size of each safety net mesh opening shall not exceed 36 square inches (230 square centimeters) nor be longer than 6 inches (15 centimeters) on any side, and the openings, measured center-to-center, of mesh ropes or webbing, shall not exceed 6 inches (15 centimeters). All mesh crossings shall be secured to prevent enlargement of the mesh opening.
- Each safety net or section shall have a border rope for webbing with a minimum breaking strength of 5,000 pounds (22.2 kilo Newton). Connections between safety net panels shall be as strong as integral net components and be spaced no more than 6 inches (15 centimeters) apart. Safety nets shall be installed with sufficient clearance underneath to prevent contact with the surface or structure below. When nets are used on bridges, the potential fall area from the walking/working surface to the net shall be unobstructed.
- Safety net should be 10:5 meter and double mesh (Man & material fall arrester)



*Safety net installed below the roof truss for height work*

## 1.4 Scaffolds:

### 1.4.1 Minimum safety requirements:

- Only skilled workmen under the supervision of a competent person shall carry out the scaffold erection. Scaffolding erection area shall be cordoned off. 'Do not Use' caution sign should be displayed on incomplete or faulty scaffolding.
- After completion of the scaffold erection, competent person should check its integrity and stability, using checklist and allow person to work on it if it found safe to work.
- Competent person should do daily inspection and certify regarding its condition. Inspection record of the same should be maintained in a specified format.
- All platforms or scaffolds shall have guardrails system. Scaffold without working platform and guardrail system will not be permitted.

### 1.4.2 The Working Platform:

- The working platform should be designed as per the anticipated load.

Light duty scaffold:	< or = 122 kg/M <sup>2</sup> (25 psf)
Medium duty scaffold:	< or = 244 kg/M <sup>2</sup> (50 psf)
Heavy duty scaffold:	< or = 366 kg/M <sup>2</sup> (75 psf)
- Platform should be made in such a way that there should not be any opening, which allow material to fall. Planks / metal decking of scaffold should be fastened at both ends and it should be laid tight.
- Proper approach ladder should be provided for scaffolds from the base level to top working platform. Ladder shall be used for climbing up and down.

## SCAFFOLD STANDARDS

### MOBILE SCAFFOLD

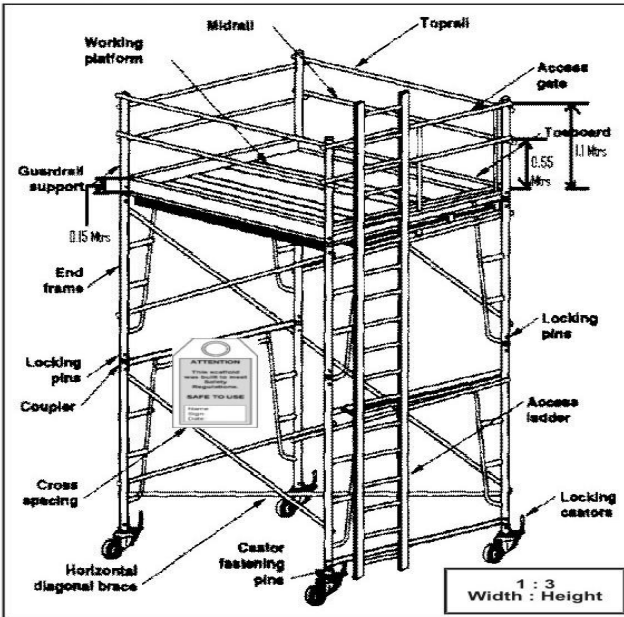

### Sole plate dimensions

Ground condition	Length (mm)	Breadth (mm)	Thickness (mm)
On hard ground	450	225	35
On soft ground	760	225	35

**Base Plate Dimensions : 150 \*150\*5 (L\*W\*T)**

### TUBULAR SCAFFOLD

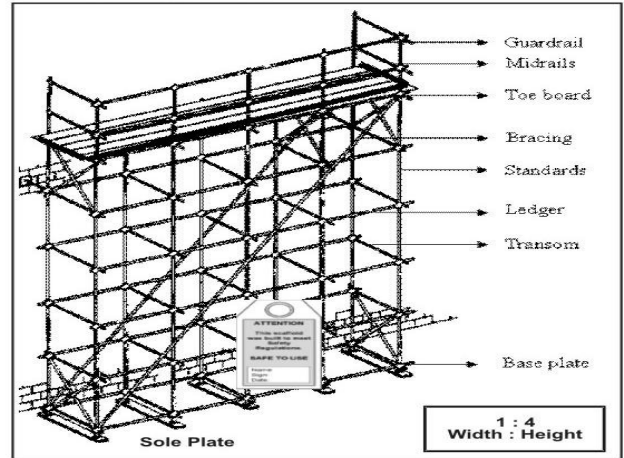

#### 1.4.3 The guardrail system:

- It should be capable of withstanding a force of at least 200 pounds (890 Newton's) applied in any outward or downward direction.
- In the guardrail system, the edge height of top rails should be 1.2 meter and mid rails should be 0.6 meter above the walking / working platform.
- Toe boards should be used as protection from falling objects; they must be erected along the edges of the overhead walking or working surface to protect persons working below. Toe boards shall be a minimum of 4.0 inches (10 centimeters) tall from their top edge to the level of the walking/ working surface.
- Where tools, equipment, or materials are piled higher than the top edge of a toe board, paneling or screening must be erected from the walking/working surface or toe board to the top of a guardrail system's top rail or mid rails, for a distance sufficient to protect employees below.

#### 1.4.4 Stability & Integrity of Scaffolds

- Scaffolds should be erected on surface that can adequately support all loads applied by the scaffolds. Mud and soft soil should be replaced with compacted gravel. Excavation near to the footing of the scaffolds should not be allowed. Proper means to be provided to avoid water penetration to the scaffold footing.
- Scaffolds erected on any type of soil should have a mudsill of 2 inch x 10 inch plant (full size) and should be continuous under at least two consecutive supports. Do not use blocking or packing such as bricks, short pieces of lumber under scaffold feet.
- The ratio of height to least lateral dimension should not exceed 3 to 1 (three to one rule) unless the scaffold is 1. Tied to a structure that should be capable of sustaining lateral loads in both tension and compression, 2. Equipped with outrigger stabilizer or 3. Equipped with suitable guy wires.



#### 1.4.5 Rolling/Mobile Scaffolds

- Height of the tower must not exceed three (3) times the minimum base dimension. Outrigger frames or outrigger units may be used to increase base width dimension when necessary.
- All casters must be secured to frame legs or screw jacks with a nut and bolt or other secure means. Weight of tower should not exceed the capacity of the casters.
- Screw jacks must not be extended more than 12 inches above caster base. Tower must be kept level and plumb at all times.
- Horizontal/diagonal bracing must be used at the bottom and top of tower and at intermediate levels of 20 feet. Fabricated planks with hooks can be used to replace the top diagonal brace.
- All frames must be fully cross-braced.
- Casters must be locked at all times, except when the scaffold is in motion
- Wheel lock should be in working condition.

#### 1.5 Ladders

- Competent person should physically verify the condition and confirmation with appropriate Indian Standards at the security gate prior to SITE entry. If it found unsafe to use, it will not be allowed inside the SITE.
- All the ladders used at SITE shall be approved by SITE Safety representative. The approval tag should be displayed all the time while in use.
- All ladder used at site should be inspected by competent person on daily basis and record should be maintained in a defined format.
- The design of ladder shall confirm to IS 1977. Make shift ladder shall not be permitted. Wooden ladder shall not be permitted at site. For working near or on electrical panel/ equipment only fiber ladder is allowed.
- Every ladder used should be of good construction, made of sound material and of adequate strength for the purpose for which the ladder or step-ladder is used;
- No ladder should be used which has a missing or defective rung or a rung which depends for its support solely on nails, spikes or other similar fixing
- A ladder should not stand on loose bricks or other loose packing and should have a level and firm footing
- Ladders used to gain access to a roof or other area shall extend at least 3 feet above the point of support.
- The foot of a ladder shall, where possible, be used at such a pitch that the horizontal distance from the top support to the foot of the ladder is one-quarter of the working length of the ladder (the length along the ladder between the foot and the support).
- Slip resistant shoe, lashing or other effective means shall be used to avoid danger of slipping.
- Extension ladder should be equipped with metal shackle and adequate locking mechanism
- Section ladder over 9.5 m in length should not be used
- Bottom and intermediate sections of sectional ladder should not exceed 2 m in length and top section should not exceed 2.75 m in length
- Step ladder should have a locking device or spreader to hold two sections firm in open position.
- Portable platform ladder should be of sound construction and provided with guardrails and toe board for its platform.
- The worker shall always face the ladder when climbing up or down.
- Short ladders shall not be spliced together to make long ladders.
- Ladders shall never be used in the horizontal position as scaffolds or work platforms.
- The top of a regular stepladder shall not be used as a step.
- Use both hands when climbing and descending ladders.
- Metal ladders shall never be used near electrical equipment.
- Holding/supporting person to there while working on A type ladder



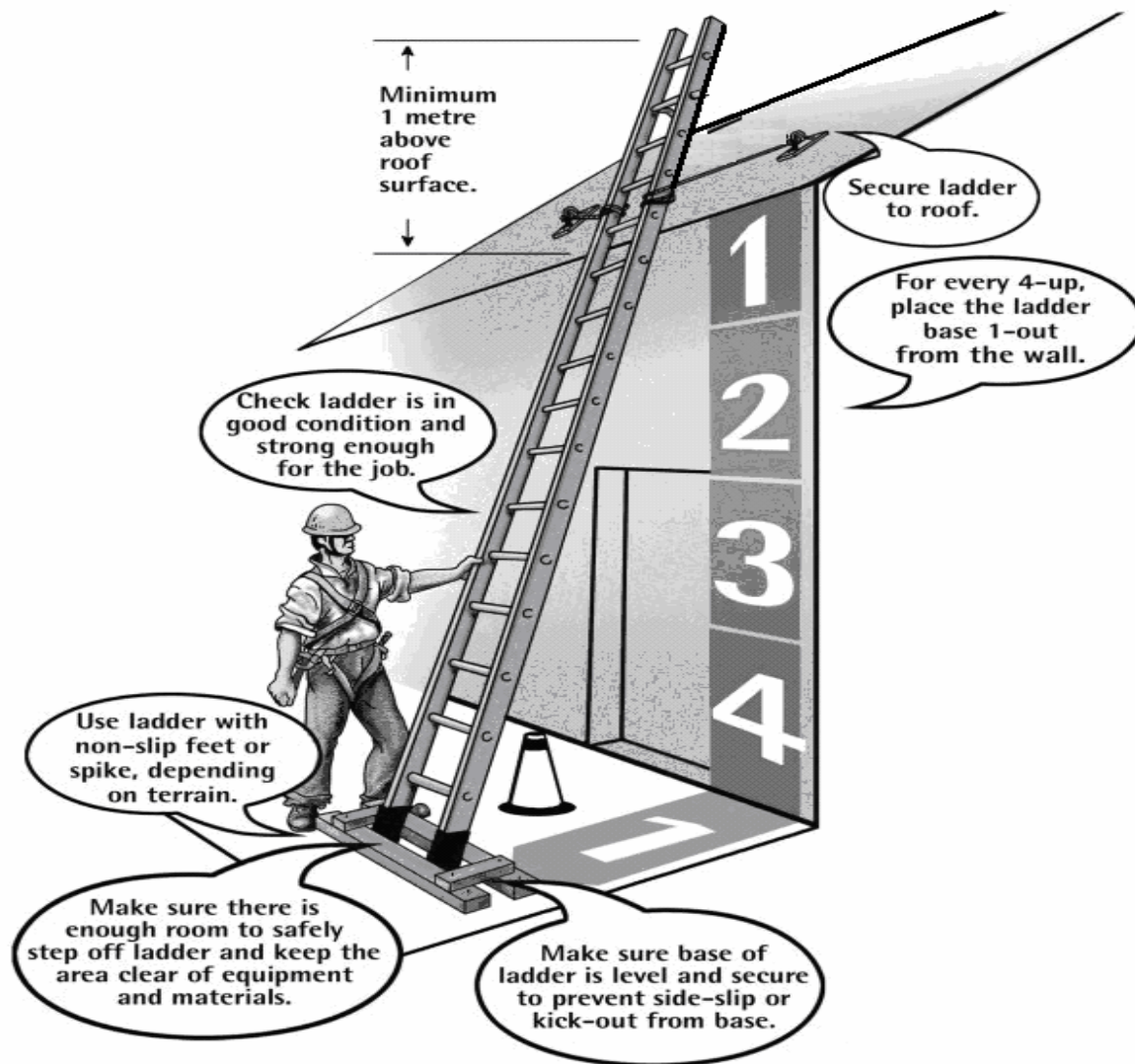

### 1.6 Slipping, tripping, cutting, drowning and falling hazard control

- All passageways, platforms and other places of construction work at the building or other construction work should be kept free from accumulations of dust, debris or similar materials and other obstructions that may cause tripping.
- Any sharp projections or protruding nails or similar projections which may cause cutting hazard to a worker should be removed or otherwise made safe by taking suitable measures by the contractor. Additional precaution has to be exercised by the contractor in handling and laying the reinforcement bars. There should not be any protruding reinforcement bars without adequate measures to make it safe.
- Contractor should not allow any building worker to use the passageway, scaffolds, platform or any other elevated working surface, which is in a slippery and dangerous condition. He should ensure that water, grease, oil or other similar substances which may cause the surface slippery, be removed or sanded, saw dusted or covered with suitable material to make it safe from slipping hazard.
- Wherever building workers are exposed to the hazard of falling into water, they should be provided by adequate equipment for saving themselves from drowning and rescuing from hazard. Wherever overhead or underground water tanks are in the construction site, measures has to be taken by the contractor in making these places safe by providing appropriate signage's, barricades and restricting the use of these areas by all workers. The contractor should have a tailor made permit system designed and implemented for regular maintenance and cleaning of these areas.

- Every open side or opening into or through which a building worker, vehicle or lifting appliance or other equipment may fall at a building or other construction work should be covered or guarded suitably to prevent fall except where free access is necessary by reason of the nature of the work.
- Wherever building workers are exposed to the hazards of falling from height while employed on work, they should be provided with adequate equipment or means for saving them from hazards. Equipment or means should be in accordance with the SAFETY Standards or as approved by the competent authority.
- Whenever there is a possibility of falling of any material, equipment on building worker at a construction site, adequate and suitable safety net should be provided by contractor in accordance with the SAFETY Standards or as approved by the Competent authority for preventing any injury or hazards.

## 2. ELECTRICAL MANAGEMENT & HAZARD CONTROL

- Electricity is extensively used in the construction site for various purposes such as driving machinery, lifting machine, motors providing general lighting, operating hand tools etc., Electricity is not dangerous, if used properly. However, if used unwisely, serious accidents can occur.
- LOTO procedure should be strictly followed as per the SITE LOTO procedures.
- All electrical distribution boards should be equipped with MCB, ELCB / RCCB. All temporary installations at a building or other construction work should be provided with earth leakage circuit breakers (ELCB). All portable electrical tools shall have double insulation and shall have upstream protection by earth leakage circuit breaker (ELCB) of less than or equal to 30 Millie Ampere rating and miniature circuit breaker (MCB).
- Any electrical connection should be taken, maintained and repaired by a qualified electrician with use of appropriate insulated tools and necessary PPEs.
- Temporary electrical wiring used for lights and power shall comply with the Indian electricity rules. All temporary electrical wiring installations, tie-ins and pick-ups shall be approved by the SITE Project Coordinator. All temporary electrical cables should be amour/metal sheathed cable to protect it from the cut due/mechanical damage.
- All portable lights for use in confined areas like manholes, or damp areas shall be operated at a maximum of 24 volts or protected by earth leakage circuit breaker (ELCB) and miniature circuit breaker (MCB).
- At the construction work where the exact location of underground electric power line is not known, the building workers using jack hammers, crow bars or other hand-tools which may come in contact with a live electrical line should be provided by the contractor with insulated protective gloves and foot-wear of the type in accordance with the SAFETY standards.
- The contractor should ensure that all electrical appliances and current carrying equipment used at a building or other construction work are made of sound material and are properly and adequately earthed. All electrical appliances should be provided with a local isolation switch close to the appliance.
- The contractor should ensure that all electrical installations are protected from rain (Weather proof shelter to be provided).
- The National Indian electric codes and regulations should apply to all permanent and temporary electrical installations.
- All current carrying parts should be enclosed and enclosure should be earthed properly.
- When high structures are moved under electrical lines, proper clearances as required should be maintained.
  - 11 KV (11000 Volts) to 33 KV (33000 Volts) - Minimum 3 meter
  - 66 KV (66000 Volts) to 130 KV (130000 Volts) – Minimum 6 meter
  - Above 230 KV (230000Volts) – Minimum 9 meter.

### **Illumination of Passageways, etc...**

The contractor should ensure that illumination sufficient for maintaining safe working conditions at a site of a building or other construction work is provided where building workers are required to work or pass and for passageways, stairways and landing, such illumination should not be less than that provided in the SAFETY standards. While working at height shadow and glare effect should minimize as it may result fall accidents.

## Sample Specification for Electrical Panel Board

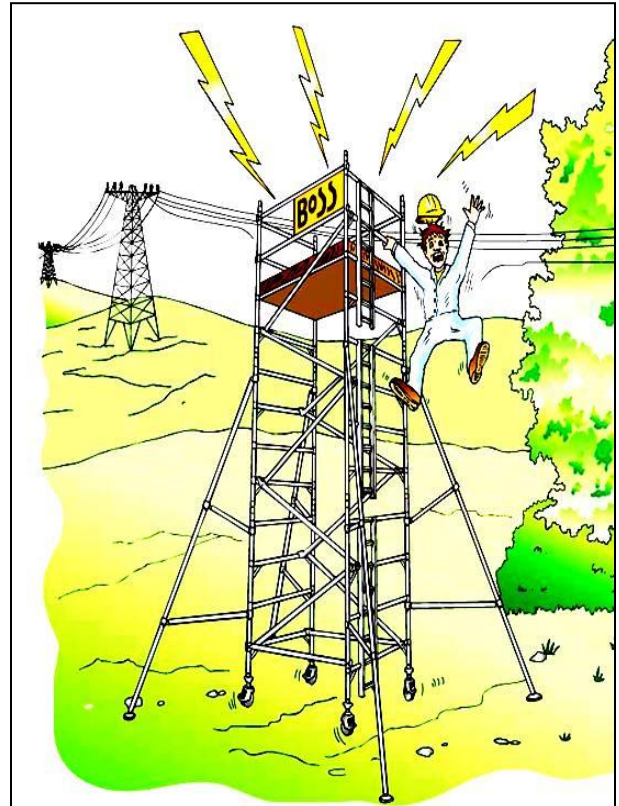
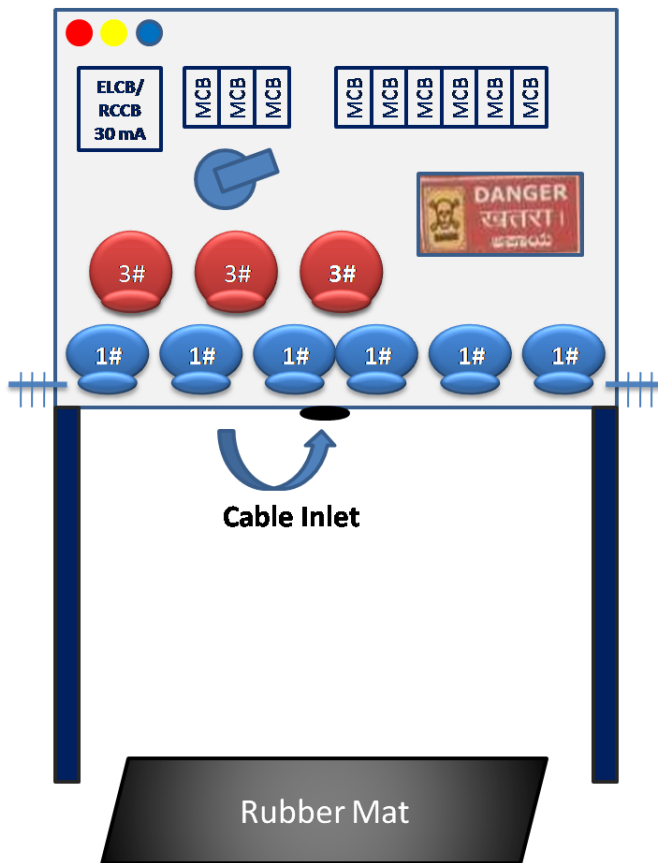

## Fundamentals of Electrical Hazards

- More than 3 mA - Painful shock
- More than 10 mA - Muscle contraction “no-let-go” danger
- More than 30 mA - Lung paralysis- usually temporary
- More than 50 mA - Possible ventricular fib (Heart dysfunction, usually fatal)
- 100 mA to 4 Amps- Certain ventricular fibrillation, fatal
- Over 4 Amps - Heart paralysis; severe burns. Usually caused by >600 volts

## Overhead Protections

- Every contractor should ensure that overhead protection is erected along the periphery of every building under construction that should be of fifteen meters or more in height when completed.
- Safety net or other means should be provided overhead protection.
- The contractor should ensure that any area exposed to risk of falling material, articles or objects should be roped off/ cordoned off /suitably guarded from inadvertent entry of person other than building workers permitted to enter these areas.

### 3. EXCAVATION & SHORING

- **Excavation** – a man-made cut, cavity, trench, or depression formed by earth removal.
- **Trench** – a narrow excavation. The depth is greater than the width, but not wider than 15 feet.
- **Shield** - a structure able to withstand a cave-in and protect employees
- **Shoring** - a structure that supports the sides of an excavation and protects against cave-ins
- **Sloping** - a technique that employs a specific angle of incline on the sides of the excavation. The angle varies based on assessment of impacting site factors

#### Procedure:

- Excavation deeper than 300 mm should be done after proper task assessment and approval from project co-ordinator.
- Proper means of access by providing ladder should be ensured in all trenches and excavation. Ladder shall be extended from bottom of trench to at least one meter above surface of the ground.
- Sides of a trench that is 1.5m or more in depth shall be stepped back to give suitable slope or securely held by timber bracing so as to avoid the danger of sides collapsing.
- Excavated material shall not be placed within 1.5m of edge of trench or half of depth of trench, whichever is more.
- Undermining or undercutting should be avoided
- Safety procedures for the operation of the excavation and grading equipment (such as the safe distance from excavations) should be developed.

## Excavation work

### Do's



Work area Barrication



Ladder for access

### Dont's

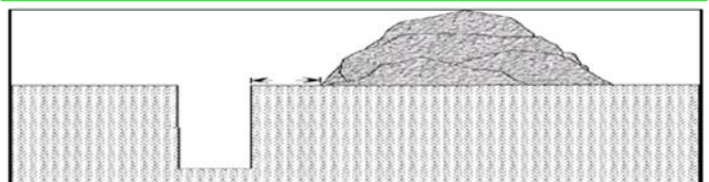

Do not dump soil near to pit



Pit without Barrication



# Barricade Standard

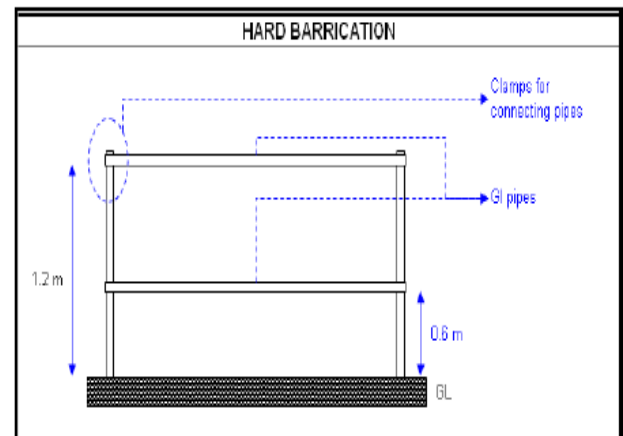
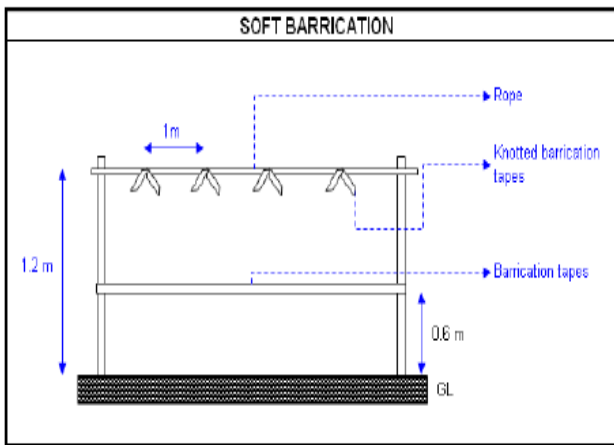

## Protection from fall, Falling Loads and Mobile Equipment.

- Install barricades
  - i) If below 1.2 mtr depth excavation - soft barricading.
  - ii) If more than 1.2 mtr depth - hard barricading- (0.6 mtr mid rail & 1.2 mtr hand rail pipe)
- Use hand / mechanical signals
- Grade soil away from excavation (Minimum 3 feet)
- Fence or barricade trenches left overnight
- Use a flagger when signs, signals and barricades are not enough protection
- Sufficient sign/display boards
- Visualization tape – such as caution tape or warning tape
- While person working at edge of the excavated pit safety belt to be worn.

## Soil Classification

The materials to be excavated shall be classified as follows unless otherwise specified.

- A) **Soft/Loose Soil** - Generally any soil which Yields to the ordinary application of pick and shovel, or to PHA WRA, rake or other ordinary digging implement; such as vegetable or organic soil, turf, gravel, sand, silt, loam, clay peat, etc.
- B) **Hard/Dense Soil** - Generally any soil which requires the close application of picks, or jumpers or scarifiers to loosen; such as stiff clay, gravel, cobblestone, water bound macadam and soling of roads.

NOTE - Cobblestone is the rock fragments usually rounded or semi-rounded having maximum diameter in any one direction between 80 mm and 300 mm.

- C) **Mud** - A mixture of soil and water in fluid or weak solid state.
- D) **Soft/Disintegrated Rock (Not Requiring Blasting)** - Rock or boulders which may be Quarried or split with crowbars. This will also include laterite and hard conglomerate.

E) **Hard Rock (Requiring Blasting)** – Any rock or boulder for the excavation of which blasting is required.

NOTE -Boulder is a rock fragment usually rounded by weathering disintegration and exfoliation or abrasion by water or ice, having maximum. Diameter in any direction of more than 300 mm. round lying loose on the surface or embedded in river bed. Soil, talus, slope wash and terrace material of dissimilar origin.

F) **Hard Rock (Blasting Prohibited)** – Hard rock requiring blasting as described under (e) but where blasting is prohibited for any reason and excavation has to be carried out by chiseling, wedging or any other agreed method.

NOTE - A broad classification of soil and rock for earthwork suitable for conditions generally occurring in practice has been provided where necessary; further sub-classification may be done to suit Individual cases depending on the properties of the substrate

### **Falls and Equipment**

- Keep materials or equipment that might fall or roll into an excavation at least 3 feet from the edge of excavations, or have retaining devices, or both.
- Provide warning systems such as mobile equipment, barricades, hand or mechanical signals, or stop logs, to alert operators of the edge of an excavation. If possible, keep the grade away from the excavation.
- Provide scaling to remove loose rock or soil or install protective barricades and other equivalent protection to protect employees against falling rock, soil, or materials.
- Prohibit employees from working on faces of sloped or benched excavations at levels above other employees unless employees at lower levels are adequately protected from the hazard of falling, rolling, or sliding material or equipment.
- Prohibit employees under loads that are handled by lifting or digging equipment. To avoid being struck by any spillage or falling materials, require employees to stand away from vehicles being loaded or unloaded. If cabs of vehicles provide adequate protection from falling loads during loading and unloading operations, the operators may remain in them.

## 4. HOT WORK OPERATION

### 4.1 Gases / Gas Cylinder management

- All compressed gas cylinder should be handled in an approved cylinder trolley. No free rolling of cylinders is allowed at SITE.
- Compressed gas cylinders shall be properly and legibly marked with the trade name of the gas content and also color coded as per Bureau of Indian Standard. When transporting, moving and storing compressed gas cylinders, valves shall be closed, and protection caps shall be in place and secured. For transportation of gas cylinder specifically designed trolleys must be used.
- Cylinder shall not be rolled for transporting from one place to another place. All cylinders shall be secured in an upright position by chains or other approved means to prevent them from accidentally falling.
- Oxygen cylinders shall be stored separately from fuel gas cylinders. No compressed gas cylinders shall be taken into confined spaces.
- Overnight storage of cylinders of compressed flammable gases or oxygen inside buildings shall not be permitted without the prior approval of the SITE Project Coordinator. Cylinders so stored shall have valves closed, regulators removed, have caps replaced, and be placed in an approved location.
- Gas cylinders shall be stored in an area assigned by the SITE Project Coordinator. This area shall be well ventilated and away from sources of ignition or heat.

### 4.2 Welding & Gas Cutting Operation

Welding and Gas cutting operation is high-risk job and should not be done without hot work permit. Area should be cleaned and free from any combustible material where welding / gas cutting operation to be carried out.

#### ➤ Welding Operation

- a. Any welding machine prior to use first time should be inspected and certified for its safe use by a competent person. All welding machine should be inspected as per the checklist for its condition once in a week and proper inspection tag should be placed on the machine.
- b. Only qualified welder is allowed to do welding with appropriate insulating hand gloves, appropriate welding shield and tools.
- c. Power to welding machine should be taken through ELCB. Welding machine should be earthed properly. Before shifting welding machine from one place to another power supply should be switched off.
- d. A portable screen should be used around the welding work area to prevent unnecessary exposure to people working in the vicinity.
- e. Sparks/hot melt should be contained by providing fire blanket / aluminum sheet barricading. Power cable and return cable should be taken up to the welding place i.e. any structural member / pipeline should not be used as return current cable.

➤ **Gas cutting operation**

- a. Gas cutting nozzles should be equipped with flash back arrester. Appropriate and ISI marked gas regulators are only allowed for Oxygen & Acetylene gas cylinder.
- b. Gas cylinder should not be exposed to sparking / heat. Acetylene cylinder should always be kept vertical position. Oxygen & Acetylene gas cylinders should be placed in cylinder trolley, free standing is not allowed.
- c. SITE Chemical & Gas handling procedures should be strictly followed for handling, storage and uses of gas cylinders.
- d. Inventory of gas cylinders should be kept as minimum as possible. Cylinder valve should be protected with secured valve cap. Free rolling of the cylinder is not allowed. Magnetic lifting of cylinder is not allowed.

## **5. Traffic Management**

- 5.1 The basic objective of the following guidelines is to lay down procedures to be adopted by contractor to ensure the safe and efficient movement of traffic and also to ensure the safety of workmen at construction sites.
- 5.2 All construction workers should be provided with high visibility jackets with reflective tapes as most of viaduct /tunnelling and station works or either above or under right-of-way. The conspicuity of workmen at all times shall be increased so as to protect from speeding vehicular traffic.
- 5.3 The guiding principles to be adopted for safety in construction zone are to
- i) Warn the road user clearly and sufficiently in advance.
  - ii) Provide safe and clearly marked lanes for guiding road users.
  - iii) Provide safe and clearly marked buffer and work zones
  - iv) Provide adequate measures that control driver behaviour through construction zones.

### **5.4 Legal permission**

- 5.4.1 In all cases, the contractor shall employ proper precautions. Wherever operations undertaken are likely to interfere with public traffic, specific traffic management plans shall be drawn up and implemented by the contractor in consultation with the approval of local police authorities and/or the concerned metropolitan/civil authorities as the case may be.
- 5.4.2 Such traffic management plans shall include provision for traffic diversion and selection of alternative routes for transport of equipment. If necessary, the contractor shall carry out road widening before commencement of works to accommodate the extra load

5.5 The primary traffic control devices used in work zones shall include signs, delineators, barricades, cones, pylons, pavement markings and flashing lights.

5.6 The road construction and maintenance signs which fall into the same three major categories as do other traffic signs, that are Regulatory Signs, Warning Signs and Direction (or guidelines) Signs shall only be used. The IRC: 67 (Code of Practice for Road Signs) provide a list of traffic signs. The size, colours and placement of sign shall conform to IRC: 67.

### **5.7 Regulatory signs**

5.7.1 Regulatory signs impose legal restriction on all traffic. It is essential, therefore, that they are used only after consulting the local police and traffic authorities.

### **5.8 Warning signs**

5.8.1 Warning signs in the traffic control zone shall be utilised to warn the drivers of specific hazards that may be encountered.



- 5.8.2 The contractor shall place detour signage at strategic locations and install appropriate warning signs. In order to minimize disruption of access to residences and business, the contractor shall maintain at least one entrance to a property where multiple entrances exist.
- 5.8.3 A warning sign shall be installed at all secondary road which merges with the primary road where the construction work is in progress at sufficient distance before it merges with the primary road so as to alert the road users regarding the ' BDA Work in Progress'.
- 5.8.4 Materials hanging over / protruded from the chassis / body of any vehicle especially during material handling shall be indicated by red indicator (red light/flag) to indicate the caution to the road users.

## **5.9 Delineators**

The delineators are the elements of a total system of traffic control and have two distinct purposes:

- i) To delineate and guide the driver to and along a safe path
- ii) As a taper to move traffic from one lane to another.

- 5.9.1 These channelising devices such as cones, traffic cylinders, tapes and drums shall be placed in or adjacent to the roadway to control the flow of traffic. These should normally be retro-reflectors complying to IRC: 79 - Recommended Practice for Road Delineators.

### **5.9.2 Traffic cones and cylinders**

Traffic cones of 500mm, 750mm and 1000mm high and 300mm to 500mm in diameter or in square shape at base and are often made of plastic or rubber and normally have retro- reflectorised red and white band shall be used wherever required.

### **5.9.3 Drums**

Drums about 800mm to 1000mm high and 300mm in diameter can be used either as channelising or warning devices. These are highly visible, give the appearance of being formidable objects and therefore command the respect of drivers.

### **5.9.4 Barricades**

- 5.9.4.1 Full height fence, barriers, barricades etc. shall be erected around the site in order to prevent the working area from the risk of accidents due to speedy vehicular movement. Same the way barricades protect the road users from the danger due to construction equipment and other temporary structures.  
BDA logo and other details shall be in accordance with specifications and instructions by Engineer in Charge.
- 5.9.4.3 All barricades shall be erected as per the design requirements of the Employer, numbered, painted and maintained in good condition and also Barricade in-charge maintains a barricade register in site.
- 5.9.4.4 All barricades shall be conspicuously seen in the dark/night time by the road users so that no vehicle hits the barricade. Conspicuity shall be ensured by affixing retro reflective stripes of required size and shape at appropriate angle at the bottom and middle portion of the barricade at a minimum gap of 1000mm. In addition minimum one red light or red light blinker should be placed at the top of each barricade.

5.9.5 The contractor shall ensure that all his construction vehicles plying on public roads (like dump trucks, trailers, etc.) have proper license to ply on public roads from the State Transport Authority. Drivers holding proper valid license as per the requirements of Motor Vehicles Act shall drive these vehicles

5.9.5 The contractor shall not undertake loading and unloading at carriageways obstructing the free flow of vehicular traffic and encroachment of existing roads by the contractor applying the excuse of work execution.

#### **5.9.7 Tow away vehicle**

5.9.7.1 The contractor shall make arrangements keeping tow away van / manpower to tow away any breakdown vehicle in the traffic flow without losing any time at his cost.

#### **5.9.8 Cleaning of roads**

5.9.8.1 The contractor shall ensure the cleanliness of roads and footpaths by deploying proper manpower for the same. The contractor shall have to ensure proper brooming, cleaning washing of roads and footpaths on all the time throughout the entire stretch till the currency of the contract including disposal of sweepage.

#### **5.10 Work to adjacent railways**

5.10.1 Whenever work is to be conducted in close proximity to the live railways then the following measures shall need to be addressed:

- (a) The rules provided for in the Railway's manual shall be followed.
- (b) No persons are allowed to encroach onto the railway unless specific authority has been given by the owner.
- (c) Adequate protection in accordance with the railway owner's requirements shall be followed. (Provision of Block Inspectors, Flagmen and Lookouts)
- (d) All persons shall wear high visibility clothing at all times.
- (e) Any induction training requirements of the railways shall be strictly observed

## **6. HAND TOOLS & POWER TOOLS**

### **6.1 Tools & Equipment**

- All power tools equipment like portable grinder, drilling machine, saw, welding machine are to be checked at SITE security gate by competent person for its conditions as per the checklist approved by SITE. Only those tools, which are found safe and having LOTO capability are allowed inside the SITE.
- Hand and power tools must be maintained in a safe condition. When power-operated tools are designed to accommodate guards, they must be equipped with appropriate guards when in use. All moving / rotating parts must be provided with 360 degree guarding.
- All hand-held pneumatic power tools must be equipped with a constant pressure switch that shuts off when the pressure is released. Pneumatic power tools must be secured to the hose or whip by positive means. Safety clips or retainers must be maintained on pneumatic impact (percussion) tools to prevent attachments from being accidentally expelled. Hoses should not be used for hoisting or lowering tools and hoses exceeding ½” in inside diameter must have a safety shutoff at the source of supply to reduce pressure in case of a hose failure.
- Abrasive wheel machine should not be operated more than the manufacturer’s recommended speed. All employees using abrasive wheels must have eye protection and other tools must be operated using appropriate personal safety equipment.
- Electric power-operated tools should be of the approved double insulated type, or grounded in accordance with good electrical practice. It should have upstream protection through ELCB having rating not more than 30 mA. Electric power operated tools should not be lowered by holding its power cord. Use only SAFETY standard hand power tools.
- Lifting machines tools and lifting tackles must have valid competency certificate for use inside SITE. The contractor shall have register/record maintained for inspection of lifting machines tools and lifting tackles.
- Cranes, forklifts shall have valid test certificate from competent authority and prior HSE visual examination is required before entering the premises and then permission for entry will be based on the judgment of HSE expert.

#### **Fencing / Guarding of moving parts**

- Every contractor should obtain formal approval from SITE-Project authorities before bringing any equipment having moving parts into the site. These equipment should have clear specification, name plate and operation manual furnished by the manufacturer. Standard operating procedures for these machines should be submitted to SITE-project authorities and formal clearance obtained before installing and trail run.
- All motors, cogwheels, chains, and friction gearing, flywheels, shafting, dangerous and moving parts of machinery (whether or not driven by mechanical power) should be securely fenced or lagged.
- Fencing of dangerous parts of machinery should not be removed while machinery is in motion or in use.
- Contractor should develop equipment specific LOTO procedure for all critical equipment, electrical distribution boxes, junction boxes etc.,
- No part of any machinery which is in motion and which is not securely fenced should be examined, lubricated, adjusted or repaired except by a person skilled for undertaking examination, lubrication, adjustment or repairs.
- Any activity mentioned above should be undertaken by a trained and responsible person by applying LOTO procedure.
- When a machine is stopped for servicing or repairs, adequate measures should be taken to ensure that these machines does not re-start inadvertently. LOTO procedure should be followed.

## 7. MATERIAL HANDLING AND CONSTRUCTION EQUIPMENT SAFETY

### Mechanical Handling

The safe way of using mechanical equipment is to have properly trained operations, running equipment that is well maintained and carrying out the work for which it was designed.

#### 1. General Requirements

- All machinery should be inspected before placed in service and at regular intervals thereafter.
- No repair, adjustment, or replacement of parts on moving machinery is permitted. Before making any repairs all equipment must be stopped and deactivated so that it cannot be unintentionally started.
- At the start of each shift, the operator must check oil, water, fuel, and hydraulic levels, that all gauges are operating and the machine is functioning smoothly. Safety equipment (e. g, guard, limit switches) must be checked daily
- Equipment travelling or working on the highway must have light and reflector. Park the equipment clear of the roadway. If this is not possible, use flashing light, cones, or other warning devices to alert approaching traffic.
- When vehicles are left unattended (Even overnight), engines must be stopped, parking brakes applied and the wheels chocked. Blades, scraper bowls, and other hydraulic equipment must be lowered to the ground before the operator leaves the machine. The ignition key should be removed and/or battery cables disconnected to avoid start-up by unauthorized personnel.
- Cabs fitted to equipment must give 360 degree visibility. Cabs must be kept clean and clear of such items as rubbish and loose tools.
- Equipment must be located so that exhaust fumes will not affect workers in the area. Gasoline-driven equipment shall not be used inside a building or other confined space.
- Contractor should ensure that all vehicles used at construction site comply with the requirements of the Central Motor Vehicles Act, and the rules made there under.
- Contractor should also ensure that a driver of a vehicle of any class of description operating at a construction site holds a valid driving license under the Motor Vehicles Act/Rules.
- All vehicles that are used on construction site must be in fit condition and should carry proper fitness certificate. Before entering SITE, all vehicles should be checked for condition, driver license, brakes and other controls, lights. Checklist given by SITE should be complied before allowing any vehicle at SITE
- Many accidents at work places are caused by undue haste or short-cut methods in executing work. Vehicle should follow speed limit (20 kmph) and defined routes only. No vehicle should be allowed unattended in ON condition or keeping start key in position.
- Electric supply lines, telephone lines and water supply lines normally go along the road side and cannot be protected at all times. Careless driving can disturb these essential services. The driver should be specifically instructed to avoid any damage to these essential services.
- Vehicle should be loaded as per the loading capacity specified by the manufacturer. Any vehicle that is overloaded will not be permitted within the SITE construction site
- Protective embankments should be provided at all excavation sites. They are particularly necessary where Lorries or dumpers trip into excavations. Stops made of bulk timbers of about 300 mm square, securely anchored, are normally used for this purpose. Care must be taken to ensure that the timbers are moved and relocated as necessary when the work proceeds.
- The design and placement of overhead barriers as well as storing of metallic objects should be at a safe distance from the overhead lines. Where no work is done under the overhead lines nor any traffic or plant pass under them, the barriers should prevent inadvertent close approach. Where the work or traffic flow is under the

overhead lines, defined access ways should be laid out. If work is done beneath the lines, expert advice for additional precautions should be obtained from the local electricity authorities, recorded and complied with.

## 2. Compressors

Compressors are one of the most common equipment used in construction work. That can be used to supply air for portable power tools or to supply air to sustain men working with breathing apparatus in extremely hazardous atmosphere. There is a considerable difference in the quality of the air used for these two functions.

- All employees on site must know the dangers of compressed air. Never use compressed air to dust off clothing or machinery. When compressed air is used in special cleaning, goggles and full face shield must be worn.
- Compressors must be properly designed, inspected, tested and maintained relief valves shall be installed and the air receiver must be periodically inspected.
- Before start up a daily check should be made of the compressor's pressure relief valve, fuel, oil and water levels and the air reservoir should be drained of trapped water.

### When compressors supply air for breathing:

1. The air intake must be located so that it does not draw in exhaust gas.
2. There must be a filter to remove oil mist.
3. They must be equipped with an automatic high temperature alarm.
4. The air must be tested periodically to be certain it is safe to breathe.

## 3. Concrete Mixers and Batching Plants

A concrete mixer of some type will be used on almost every construction site. The principles of good maintenance and properly trained operators apply equally whether it is only a small mixer for masonry work.

- A chains, gears, and revolving shafts must be guarded.
- Safety Chains and catches must be operative, and the lifting mechanism must be in good order.
- Men must not be allowed to work under or near the loading skip unless it is held in position by a safety chain.
- The mixer drum and the area around the machine must be thoroughly cleaned at end of each day's operation.
- Cement bags must not be allowed to accumulate in the mixer area; that should be collected and disposed of at regular intervals during the day.
- The approach to the sand and aggregate bins should be barricaded, and the barricades should only be removed to allow access for vehicles delivering material.
- Personal protective equipment such as respirators ear muff, and goggles shall be worn. Loose fitting clothes shall not be worn around moving machinery.
- Lockout and tag out system is required in batching plants to ensure the safety of repair or maintenance personnel. Lock out and tag out system rules must be posted in a conspicuous location throughout the plant and workers must be thoroughly trained in the lockout/tag out procedures.

## 4. Dumpers and Dump Trucks

Dumpers and dump trucks commonly used for construction work, often travel on the public highway. Therefore it is essential that they should be properly maintained.

- Dumpers are not designed to carry passengers. It must be strictly forbidden for employees to ride in the skip or on engine cover.



- When repairs or maintenance are being carried out on a hydraulically operated dump truck, the dump truck body should be fully lowered. If it is necessary to have it in the raised position, it must be blocked. Do not rely on the hydraulic ram to support the raised body for an extended period.
- All vehicles with cabs shall be equipped with windshield and powered wipers. Cracked or broken windshields or windows shall be replaced.

## 5. Excavators

Excavations are carried out using very specialized equipment which roughly falls into two categories: 1) Fixed position machines, and 2) moving machines.

Fixed position machines include, but are not limited to face shovels, backhoes, and grabs. The “Fixed” excavator loosens the soil and loads from a stationery position. They are useful to perform specific excavation tasks at a single location. Their loss of mobility is compensated by the fact that greater force can be applied at the excavation face.

“Moving” machines include, but are not limited to, bulldozers, loaders, scrapers, graders and trenching machines. They remove, transport and deposit excavated material all in one cycle of operation. They are used in applications where large volumes of earth need to be moved over uneven ground. In this process, they also help to level the ground over which they operate.

## 6. Fork Lift Trucks

Fork lift trucks are designed to operate on firm, level ground. This type of equipment has a limited use in construction operations. They are, however, sometimes used in materials handling yards and for placing loads where there are firm ground conditions. The truck shall be equipped with overhead protection.

When travelling with a load on the forks, the forks should be as low as possible to maintain stability.

If the load being carried obstructs the operator’s forward view, he should travel in reverse.

## 7. Crane & Lifting Equipment

- All lifting appliances, including their parts and working gear, whether fixed or moveable and any plant or gear used in anchoring or fixing of appliances, should conform appropriate Bureau of Indian Standards and be of sound construction, sound material, and of adequate strength and maintained in good working condition.
- Every lifting appliance should be provided with adequate and efficient brakes/control measures. Test and periodical examination of lifting appliances.
- All lifting appliances including all parts and gears, whether fixed or moveable, should be tested and examined by a competent person in the following circumstances:
  - before being taken into use for the first time
  - after it has undergone any alterations or repairs liable to affect its strength or stability
  - or after erection on a construction site
- All lifting appliances should be thoroughly examined by a competent person once at least in every twelve months and the record of examination should be maintained.

**Automatic safe load indicators.**

- Every crane, if so constructed that the safe working load may be varied by raising or lowering of the jib, should be attached with an automatic indicator of safe working loads which give a warning to the operator wherever the load exceeds the safe working load
- Cut-out should be provided which automatically arrests the movements of the lifting parts of every crane if the load exceeds the safe working load, wherever possible.
- In case it is not possible to install an automatic safe load indicator, in which case, provision of a table showing the safe working loads at the corresponding inclinations or radii of the jib on the crane will be considered sufficient.

#### **Identification and marking of safe working load.**

- Every lifting appliance and loose gear should be clearly marked for its safe working load and identification by stamping or other suitable means;
- Every derrick (other than derrick crane) should be clearly marked for its safe working load.
- The lowest angle to the horizontal, to which the derrick may be used, should be legibly marked;
- Every lifting appliance having more than one working load should be fitted with effective means to enable the operator to determine safe working load at each point under all condition of use.
- No lifting appliances or lifting gear should be used unless marked as per SAFETY provisions.

#### **Operation of lifting appliances**

- Every crane driver or lifting operator should possess adequate skill and training in the operation of the particular lifting appliance;
- Person above eighteen years of age should be in control of any lifting appliance, scaffold winch, or to give signals to the operator;
- Precaution should be taken by the trained operator to prevent lifting appliance from being set in motion;
- The operation of lifting appliance should be governed by signals, in conformity with the SAFETY standards;
- The lifting appliance operator's attention should not be distracted while he is working;
- No crane, hoist, winch or other lifting appliance or any part of crane, hoist, winch or other lifting appliance should not be loaded beyond the safe working load, unless used for testing purpose in the presence of competent authority;
- During the hoisting operations effective precaution should be taken to prevent any person from standing or passing under the load.
- Operator should not leave lifting appliance unattended while power is on or load is suspended.
- No person should ride on a suspended load or on any lifting appliance;
- Every part of a load in course of being hoisted or lowered should be adequately suspended and supported to prevent danger;
- Every receptacle used for hoisting bricks, tiles, slates or other material should be suitably enclosed so as to prevent the fall of materials;
- The hoisting platform should be enclosed when loose materials or loaded wheel-barrows are placed directly on platform for hoisting or lowering of materials.
- There should not be sudden jerk to any lifting appliances while the material is being raised, lowered or slowed.
- In hoisting a barrow, any wheel of barrow should not be used as a means of support unless adequate steps are taken to prevent the axle of wheel from slipping out of its bearings;
- Long objects like planks or girders should be provided with a tag line to prevent any possibility of danger while raising or lowering.
- During the process of landing of material, a building worker should not be permitted to lean out into empty space for finding out the loading and unloading of material;
- The hoisting of loads at places where there is regular flow of traffic should be carried out in an enclosed space. In case it is impracticable, suitable measures are to be taken to hold up or divert the traffic during the time of hoisting

- Adequate steps should be taken to prevent a load, in the course of being hoisting or lowered from coming into contact with any object to avoid any displacement.

## 8. Tower Cranes

- Tower cranes should be operated by trained operator capable of working at height. The operator should also be trained in using full body harness system.
- The ground on which a tower crane stands should have adequate bearing capacity;
- Bases for tower cranes should be firm and leveled and cranes should be erected at a reasonably safe distance from excavations. These cranes should be operated within gradient limits as specified by the manufacturer of cranes;
- Tower cranes should be sited where there is a clear space available for erection, operation and dismantling of cranes;
- Tower cranes should be sited in a way that the loads on cranes are not handled over any occupied premises, public thoroughfares, near power cables, other than construction works for which such cranes are intended
- Where two or more tower cranes are sited and operated, every care is taken to ensure positive and proper communication between operators of cranes to avoid any danger or dangerous occurrences;
- The instructions of the manufacturer of a tower crane and standard safe practices regarding cranes should be followed while operating or using crane.
- The Tower crane installation, jacking operation and operating procedure must be submitted for review. Trained crew having 5+ years experience should be engaged in installation & jacking operation of the tower crane.
- During installation of power crane, the area must be barricaded & inspection has to be made with checklist before operating the crane.

# Hand signals for hoist and crane operations

If hand signals are used between a signaller and the operator of a crane or hoist to control hoisting operations, the following signals should be used:

## STOP

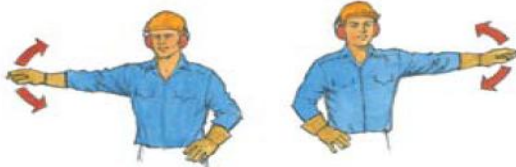

Arm extended, palm down, move hand horizontal.

## HOIST



With forearm vertical, finger pointing up, move hand in small horizontal circles.

## LOWER



With arm extended down, move forefinger; pointing down, move hand in circles.

## RAISE BOOM

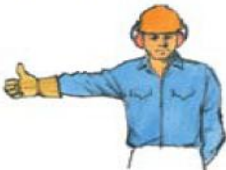

Arm extended, fingers closed, thumb pointing upward.

## LOWER BOOM



Arm extended, fingers closed, thumb pointing downward.

## RAISE THE BOOM AND LOWER THE LOAD



With arm extended, thumb pointing up, flex fingers in and out as long as load movement is desired.



Arm extended, fingers closed, thumb pointing upward, other arm bent slightly with forefinger pointing down, and rotate hand.

## LOWER THE BOOM AND RAISE THE LOAD



With arm extended, thumb down, flex fingers in and out as long as load movement is desired.



Arm extended, fingers closed, thumb down, other arm vertical, forefinger upward and rotate hand.

## EXTEND BOOM



Both fists in front of body, with thumbs pointing outward.

## RETRACT BOOM



Both fists in front of body, with thumbs pointing toward each other.

## SWING



Arm extended, point in direction of swing of boom.

## MOVE SLOWLY



Use one hand to give any motion signal and place other hand motionless in front of hand giving the motion signal (hoist slowly shown as example)

## DOG (STOP) EVERYTHING



Clasp hands in front of body.

## Chemical Management

- Any chemical brought inside the SITE should have material safety data sheet (MSDS)
- All containers shall be properly labeled with name, manufacturer's name, hazard warning symbol and PPE and properly always capped, when not in use. All chemical container should be stored in a secondary container
- Workers using chemical must be trained & well versed with the hazards & precaution to be taken during the use & during emergency. Require antidote, safety kit must be made available.
- Flammable or combustible liquids shall not be stored in areas used for exits, stairways or normally used for the safe passage of pedestrian or vehicular traffic.
- Inventory of combustible materials shall be kept at a minimum as reasonably practicable and other combustible material shall not be allowed to accumulate to the extent of creating a fire hazard.

- The Contractor shall be responsible to clean the site and handle the waste generated by his work activities and dispose of properly in environmental friendly manner outside the premise. The disposal site must be approved by competent authorities.

### **Housekeeping**

Safety is related to good housekeeping. It includes the following:

- Working premises is clean and tidy.
- Passage ways marked and clear of all obstructions.
- Material well stacked and neatly placed.
- No dangling of electric or phone wires at construction sites.
- Roads clean, well watered and well drained
- Environment well lighted, particularly during the night shift

Contractor has to ensure that adequate resources and process are deployed for maintaining good housekeeping at all times. This should include deployment of housekeeping squad for daily removal of unwanted material such as metal support members, shuttering forms, scaffolds, nails, construction debris etc. This can be done by properly organizing construction steps.

Contractor must ensure that proper access is established for material and manpower movement. Daily inspection teams should be in place for inspecting each area of construction site for checking all passage ways, access, emergency exit, etc., appropriate signage should be installed.

Contractor should also ensure that waste or trash bins are provided at designated locations. Proper segregation of waste such as oily rags, metal scrap, insulation material or other non-metal scrap is handled appropriately. These bins must be cleared on pre-determined frequency. The contractor should establish a written program of “site specific waste disposal from the construction site” and approval of Site-project representative and HSE should be obtained before implementing it on site. The contractor should be fully in compliance with all legislations applicable to environment, pollution and waste management. Contractor must identify the Govt. approved site for disposal of this non hazardous waste. This waste is not permitted to be dumped on private or any unapproved site. The contractor and the sub contractors must obtain appropriate licenses or approvals from the local regulatory agencies for the disposal of the waste. A copy of the approval should be submitted to the project coordinator or SITE project representative.

A permanent dedicated housekeeping team in proportion to the size of the project to be deployed at the site for regular housekeeping activities.

### **Tips for maintaining good housekeeping within the premises**

- All working places, working rooms, passages, storerooms, office rooms, etc., should be kept in clean and hygienic condition.
- The floor of every working room and other places should be maintained clean and as far as practicable dry and non slippery.
- All toilets, washbasins, drinking water points etc., should be maintained in hygienic condition.
- Adequate number of waste containers should be provided in all the places and these should be emptied periodically.
- Supervisors should ensure that the employees are properly instructed to maintain good housekeeping in their respective areas.



- Any spilled oil, grease, acid or alkaline materials, should be cleaned immediately.
- Access to safety and fire fighting equipment's, electrical control panels, and safety showers should be kept clear.
- Passages, walkways, staircases, etc., should not be obstructed.
- No pipes, hoses, etc., should be run across pathways.
- Materials with protruding nails/sharp edges should not be left lying around.

#### **Disposal of Debris**

- Debris should be handled and disposed of by a method which does not cause danger to the safety of a person and is in adherence to legislations where applicable.
- Debris should not be allowed to be accumulated so as to constitute a hazard
- Debris should be kept sufficiently moist to bring down the dust within the permissible limit;
- Debris should not be thrown inside or outside from any height.
- On completion of work, left over building material, article or other substance or debris should be disposed of as soon as possible to avoid any hazard to any traffic or person.
- Debris should not be disposed outside the SITE without prior approval of SITE HSE Team

#### **Stacking and Un-stacking of materials and articles**

- All building materials should be stored or stacked in a safe and orderly manner to avoid obstruction of any passageway or place of work; care should be taken to ensure that emergency exits are not blocked by any materials.
- Material piles are stored or stacked in such a manner so as to ensure stability.
- Material or equipment should not be stored upon any floor or platform in such quantity so as to exceed its safe carrying capacity.
- Material or equipment should not be stored or placed so close to any edge of a floor or platform so as to endanger the safety of persons below or working in the vicinity.
- Where stacking, un-stacking, stowing or un-stowing of construction material or article, or handling cannot be safely carried out unaided, all measures to guard against accident or dangerous occurrences should be taken by shoring or otherwise to prevent any danger likely to be caused by handling.
- Stacking of material or article should be made on firm foundation not liable to settle and deviate, material or article should not overload the floor on which stacking is made.
- The material or articles should not be stacked against partition or walls of a warehouse or stores place unless it is proved that partition or the wall is of sufficient strength to withstand the pressure of materials or articles.
- The materials or articles should not be stacked to a height and in a manner so as to render the pile of stack unstable and cause hazards.
- Where the building workers are working on stack exceeding one point five meters in height, safe means of access to the stack should be provided.
- All stacking or un-stacking operations should be performed under the supervision of a responsible person.
- Stacking of construction materials or articles should not be made near the site of excavation, shaft, pit or any other opening;
- Stacks that may lean heavily, unstable or may likely to collapse should be barricaded.
- All racks used for stacking must be grouted and anchored to prevent fall or collapse.

#### **Stacking of Cement and other material bags.**

- A stack pile should not be more than ten bags in height unless stack pile is stacked in a suitable enclosure or otherwise adequately supported;

- While removing bags from the stack pile, the stability of stack pile should be ensured;
- Bags containing cement or lime should be stored in dry places;
- Materials like bricks, tiles or blocks should be stored on a firm ground;
- Reinforcing steel should be stored according to its shape, size and length;
- Stack of reinforcing steel should be kept as low as possible;
- No pipe should be stored on rack or in stack where pipes are likely to fall by rolling;
- The angle of repose should be maintained where loose materials are stacked;
- When dust laden material is to be stored or handled, measures should be taken to suppress the dust produced by storing or handling and suitable.

The building workers working for storing or handling should use appropriate personal protective equipment.

### **Lifting and carrying of excessive weight**

Contractor should comply with the following guidelines for lifting and carrying of articles in the construction weight:

- Worker's should not lift any material, article, tool or appliances by hand or carry overhead or over his/her back or shoulders exceeding in weight the maximum limits shown below unless aided by any other building worker or a mechanical device.

<b>Person</b>	<b>Maximum Weight/ Load</b>
Adult – Man	50 Kg.
Adult – Woman	30 Kg.
Adolescent – Male	30 Kg.
Adolescent – Female	20 Kg.

- No building worker aided by other building workers, should lift by hand or carry overhead or over their back or shoulders, any material, article, tool or appliance exceeding in weight the sum total of maximum limits set out for each building worker separately as indicated above, unless aided by a mechanical device.

## 8.0 Fire Safety

Fire is a chemical reaction in which heat and light are evolved. It is considered that for fire to occur 3 factors are necessary.

A combustible substance or fuel, heat and oxygen. Fire will continue as long as these 3 factors are present. Removal of one of them leads to extinction of fire.

Combustible materials must meet certain requirements before it can oxidize. The relative construction is described in terms of percentages. When a concentration of gas falls into the range where it can ignite, it is said to be within its flammable or explosive limits.

Materials	Lower Explosive Limit (LEL)	Upper Explosive Limit (UEL)
Acetone	2.6	12.8
Butane	1.9	8.5
Kerosene	0.7	5.0
Natural Gas	6.5	17.0
Gasoline	1.5	7.6
Carbon Monoxide	12.4	74.0

### Classification of Fire

Class of Fire	Description	Type of fire Extinguisher
A	Fire due to combustible substance Ex: Paper, Wood, Cloth, Rubber, Plastics, Grass etc. Where cooling effect of water is essential to extinguish	Water, DCP, Foam
B	Fire in Flammable liquids Ex: Petroleum products, Oils, Solvents, Grease, Paints etc. Where blanketing effect is essential	Foam, DCP, CO <sub>2</sub>
C	Fire arising out of gaseous substances including liquefied gases Ex: Acetylene, Hydrogen, LPG etc. Where it is necessary to dilute the burning gas at a fast rate with an inert gas or powder	Water, DCP, CO <sub>2</sub> & Foam
D	Fire involving metals Ex. Magnesium, Aluminium, Zinc, Potassium, Sodium etc...	DCP
E	Fire involving electrical equipment and delicate machinery Ex: Cables, Transformers, Motors, Computers etc..	CO <sub>2</sub>

## Method of Extinguishment

- **Starvation** : Limitation or removal of fuel from the scene of fire.
- **Smothering** : Limitation or removal of oxygen from the scene of fire.
- **Cooling** : Limitation or removal of heat from the scene of fire.
- **Inhibiting** : Checking or stopping the exothermic reaction of substances which contains oxygen within them.

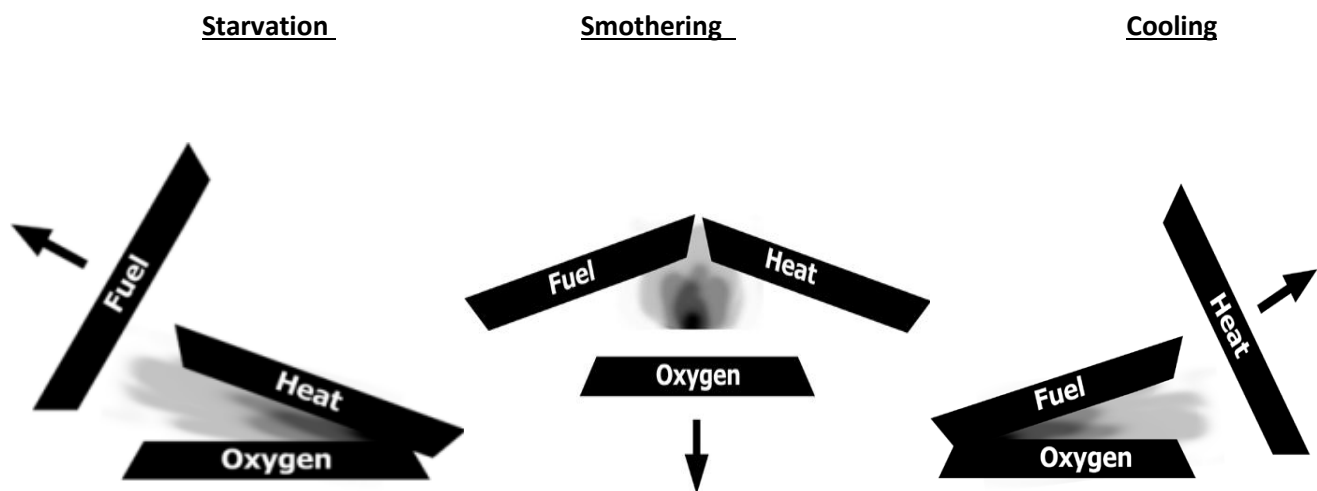

## Causes of Fire

- Smoking
- Electricity
- Welding & Cutting
- Flammable materials
- Chemicals
- Bad housekeeping
- Machinery

## Contractor should ensure that construction site is provided with –

- Fire extinguishing equipment sufficient to extinguish any probable fire at construction site;
- Adequate water supply at the site for fighting fire
- Number of trained persons required to operate the fire extinguishing equipment
- Fire extinguishing equipment provided should be properly maintained and inspected at regular intervals (every week) by the responsible person and a record of such inspections should be maintained

## General Fire Safety Precautions

- Work Permit system checklist to be followed at construction site
- Only flameproof lights should be used in the areas where flammable gases/vapors are present.
- Ruby Safety bins should be kept closed and emptied regularly.
- Good housekeeping should be maintained.
- Any leakage of flammable liquids/gases should be attended promptly.

Care must be taken to prevent fire at construction site. All the project stores must be organized in such a way that all flammables are stored separately with proper lid in secondary containment with hazard communication labels. Gas cylinders should not be placed in the contractor shed. Gas cylinders must be placed under shade. All other construction material must be organized on racks with proper labels.

Oily rags collection bins and other trash bins must be provided at strategic locations and cleared on regular basis. Oily rags should not be dumped on open ground, as it will contaminate soil & ground water.

The source of ignition such as welding work, gas cutting, grinding, drilling or other must be controlled through safe operating procedures or work permits. Smoking must be prohibited in construction area. Proper measures should be taken to contain sparks from welding, gas cutting and grinding activities

**Follow the "PASS" procedure while using the fire extinguisher for extinguishing fire.**



## EMERGENCIES

Contractors should familiarize their personnel with fire alarm, exit routes and emergency procedures, including emergency telephone numbers. These numbers and evacuation routes should be displayed at all vantage points Contractor should ensure that proper & sufficient lighting is available at each location workers are working and at each exit route. Exit route should be made clear from obstructions & must be designed to allow free discharge/ exit during emergency.

**In case of emergency of any kind** including fire, medical, security, and release of harmful material to the environment contractor shall contact site's emergency telephone number.



## Emergency Preparedness – Incase of Fire

- Alarm the people around you and call the fire brigade if necessary.
- If paper or clothes catch fire, pour water on them. Never pour water on electrical fire.
- In case of electrical fire. Switch off the mains and use sand or CO2/DCP fire extinguisher
- When clothes are on fire, pour water if available, otherwise drop to the ground and roll.
- Do not run, crawl. Cover your nose with wet cloth if possible.
- Don't use lift. Use staircase to escape.
- In case of big fire, advice everyone to leave. Do not stay back to collect important things.
- Do not hide in toilet/bathrooms. If trapped in a room, go to a window and draw the attention of people outside.
- Help physically challenged person if any to escape.
- Display telephone numbers of First Aid Emergency Services at important place.

## 9.0 WORK IN CONFINED SPACE

A confined space is a place with a restricted means for entry or exit, where harmful substances, lack of oxygen and other hazards may increase the risk of injury to those entering the space.

A confined space is any space that is large enough and so configured that an employee can bodily enter and perform assigned work, that has a restricted means of entry or exit, and that is not designed for continuous employee occupancy. In the construction industry confined spaces may be air conditioning ducts, crawl spaces, pits, trenches, pipes, sewers or box beams.

All employees who are required to work in a confined space should receive full information, instruction and training in relation to hazards and risks and be made aware of the relevant risk assessment for the confined space work.

The risk assessment should include the following control measures.

An entry permit signed on and off by the immediate supervisor describing:

- The confined space that the permit applies to
- The measures for control of risks
- The names of the employees approved to enter the space
- The name of the stand-by person assigned to the confined space
- The period of time for which the permit is valid



Stand-by arrangements for:

- Special precautions shall be taken against oxygen deficiency and the presence of toxic gases and flammable vapors in all types of confined work places.
- Proper task risk assessment should be carried out for each activity which required work in confined space and should be approved by SITE Project Coordinator and HSE.
- Signboard should be displaced at entry of confined – “Man Is Working Inside’
- Attendant without additional duties shall be provided for each confined space
- Confined spaces shall include but are not limited to storage tanks, process vessels, ventilation or exhaust ducts, sewers, underground utility vaults, tunnels, manholes and pipe lines.
- Continuous communication between the persons in the confined space and a responsible person on the outside
- Emergency procedures that can be initiated from outside the space
- The procedure to know when employees have entered or exited the confined space
- Emergency procedures for rescue and first aid
- Always use an Air Quality Monitor before entering a confined space.

**Note: Never enter a confined space unless you have been fully trained and a documented risk assessment has been completed.**

## 10. DEMOLITION OF BUILDING AND STRUCTURE

### Concrete Work

- Any building worker handling cement or concrete should –
  1. Wear close-fitting clothing, gloves, helmet or hard hat, safety goggles, proper footwear and respirator or mask to protect him/her from danger of handling;
  2. Keep as much of his/her body covered as is required to protect him/her from danger of handling;
  3. Takes all necessary precautions to keep cement and concrete away from his/her skin in handling.
- Formwork and shores used for concrete work should be structurally safe and should be properly braced or tied together so as to maintain position and shape of formwork or shores;
- Moving parts of the elevators, hoists, screens, bunkers, chutes, grouting equipment used for concrete work, other equipment used for storing, transport and handling ingredients of concrete should be securely fenced to avoid contact of workers with moving parts.
- Screw conveyers used for cement, lime and other dusty materials should be completely enclosed.
- Concrete buckets used with cranes or aerial cableways should be free from projections from which accumulations of concrete could fall;
- Movements of concrete buckets should be governed by signals necessary to avoid any danger by movements.
- A scaffold carrying a pipe for pumping/pumped concrete should be strong enough to support the pipe at time when pipe is filled with concrete or water or any other liquid and in addition bear all the load of workers who may be on scaffold, safely;
- Vibrator used in concreting work should be operated by a building worker, who is in good physical condition.
- All practical measures should be taken to reduce the amount of vibration transmitted to the operators working in concreting work. Workers operating vibrators should use appropriate PPE's
- When electric vibrators are used in concreting work, vibrators should be earthed, the leads of vibrators should be heavily insulated and the current should be switched off when vibrators are not in use.

## DEMOLITION

### Preparatory Operations

- When the demolition of any building or structure might present danger to the workers or the public:
  1. Necessary precautions, methods and procedures should be adopted, including those for the disposal of waste or residues.
  2. The work should be planned and undertaken only under the supervision of a competent person.
- **Before demolition operations begin:**
  1. Structural details and builders drawings should be obtained wherever possible.

2. Details of the previous use should be obtained to identify any possible contamination and hazards from chemicals, flammables etc.
  3. An initial survey should be carried out to identify any structural problems and risks associated with flammable substances and substances hazardous to health. The survey should note the type of ground on which the structure is erected, the condition of the roof trusses, the type of framing used in framed structures and the load bearing walls.
  4. A method of demolition should be formulated after the survey and recorded in a method statement having taken all the various considerations into account and identifying the problems and their solutions.
- All electric, gas, water and steam service lines should be shut off and, as necessary, capped or otherwise controlled at or outside the construction site before the work commences.
  - If it is necessary to maintain any electric power, water or other services during demolition, such lines shall be temporarily relocated, as necessary and protected.
  - As far as practicable, the danger zone round the building should be adequately fenced off and sign posted. To protect the public a fence 2m high should be erected enclosing the demolition operations and the access gates should be secured outside the working hours.
  - Protective clothing and respiratory devices should be provided and worn.
  - When the plant has contained flammable materials, special precautions should be taken to avoid fire and explosion.
  - Care should be taken not to demolish any parts which would destroy the stability of other parts.
  - When a hazard exists from fragmentation of glass, such hazards shall be removed.
  - Demolition activities should not be carried out under adverse climatic conditions such as high winds which could collapse the already weakened structures.
  - To prevent hazards, parts of structures should be adequately shored, braced or otherwise supported.
  - Structures should not be left in a condition in which they could be brought down by wind pressure or vibration.
  - Only those stairways, passageways and ladders, designated as means of access shall be used. Other access ways shall be entirely closed at all times.
  - Where a deliberate controlled collapse technique is to be used , expert engineering advice should be obtained and:
    1. It should only be used where the whole structure is to come down because it relies on the removal of key structural members to affect a total collapse.
    2. It should only be used on sites that are fairly level and where there is enough surrounding space for all operatives and equipment to be withdrawn to a safe distance.
  - When equipment such as power shovels and bulldozers are used for demolition, due consideration should be given to the nature of the building or structure, its dimensions as well as to the power of the equipment being used.

## **Mechanical Demolition**

- If a swinging weight is used for demolition, a safety zone having a width of at least one-and-a-half times the height of the building or structure should be maintained around the points of impact.
- The weight of the demolition ball shall not exceed 50 percent of the crane's rated load.

## **Demolition of structural steelwork**

- All precautions should be taken to prevent danger from any sudden twist or collapse of steelwork, ironwork or reinforced concrete when it is cut or released.
- Steel construction should be demolished tier by tier.
- Structural steel parts should be lowered and not dropped from a height.



## 11. LOCK OUT & TAG OUT (LOTO)

### Definition:

It is a system to maintain the shutdown state of machine while doing maintenance/repair activity shortly it is referred as a LOTO system.

### Objective:

To prevent injury to servicing and /or maintenance employees due to the unexpected energizing or startup of machines, equipment or processes; or the release of stored energy.

### Purpose

- A. Keeping you safe is the purpose of LOTO
- B. Several types of energy that can harm you
- C. LOTO is used to isolate you from an energy source

### LOTO Prevents

- A. Exposure to energy
- B. Accidental starting of equipment
- C. Using damaged equipment

### Injury can result when LOTO not used

- A. Maintenance & Repair
- B. Cleaning equipment
- C. Machine Guards removed
- D. Adjustments to machinery

### Types of Energy and Hazards

- A. Electricity - Electrical Shock
- B. Chemical - Chemical Exposure & Burns
- C. Moving Machinery - Amputation, crushing from moving machinery
- D. High Temperature - Burns
- E. Hydraulic Pressure - Exposure to hot or dangerous fluids
- F. Stored Energy - can be chemical, thermal, hydraulic or gravitational

## Sample LOTO:



Pad locks (Single lock)



Multiple lock (Hasp)



LOTO Tag

## Sourcing the equipment:



Locking pad



Instrument carrying bag



Butter fly valve locking instrument



MCCB Locking



Round valve locking instrument



Plug locking Instrument

- Before you lock & tag: Know the equipment and types of energy associated with it and the maintenance you will be doing.
- Shutdown the Equipment. Use the normal shutdown procedures to prepare the machinery for Locking and Tagging. All controls should be in the OFF or Neutral position.
- Isolate the energy to the machine. Turn off main power switches. Shut all fluid isolation valves.

- Lock & Tag the Energy Sources. Put a Lock and Tag on all energy isolation devices (ON-OFF Switches DO NOT ISOLATE ELECTRICITY - USE THE MAIN BREAKER FOR THAT PIECE OF EQUIPEMENT)
- Release all Stored Energy. Block, vent and drain all fluid lines. Discharge all capacitors. Block all pieces that would be a hazard if they moved. Disconnect pneumatic lines.
- Test to ensure LOTO is effective. Check voltage on all circuits. Check pressure gages on fluid lines. Attempt to start the equipment in the normal manner. Then return all control devices to the OFF or NEUTRAL position.

### **Removal of LOTO**

- Announce that equipment is being turned on again
- Remove your lock out and tag out devices; each device must be removed by the person who put it on, unless he is absent
- Restore energy of the equipment
- Test run equipment.

## **12. ENVIRONMENTAL MANAGEMENT**

### **12.1 ENVIRONMENTAL MANAGEMENT IN SITES AND OFFICES**

#### **The following measures shall be implemented in the office:**

- Company HSE policy shall be prominently displayed in the offices and sites.
- There should be proper ventilation and adequate lighting.
- Good and regular housekeeping shall be carried out.
- Disposal of batteries, cartridges, printer ribbons shall be done through dealers.
- Old records shall be stored properly in racks / shelves. No inflammable materials shall be stored in the office.

### **RESOURCE MANAGEMENT**

#### **12.1.1 Water**

- Plumbing items shall be regularly checked to ensure that there is no leakage.
- Immediate steps shall be taken to repair the leakages.
- Sign boards shall be kept wherever water installations have been provided.

#### **12.1.2 Electricity**

- It shall be ensured that any electrical fittings / appliances not being used are switched off.
- Monitors when not in use for more than 10 minutes to be set in "Sleep mode / Power off mode.
- System to be switched off, if not in use for more than half an hour.

### **12.2 CONTROL OF NOISE POLLUTION**

#### **12.2.1 PROCEDURE**

The sources of noise pollution are

- Diesel Generator
- Vehicles
- Equipments in use

### **12.2.2 Measurement of Noise Levels:**

Measurement of noise levels is taken at 3 meters from each Plant & Machinery, in order to identify 'High Noise Areas'. Any area having more than 75 dB shall be considered as High Noise Area. In such cases, the following actions shall be taken:

- In the case of DG rooms, the following steps shall be taken:
  - ❖ DG to be provided with acoustic enclosure as per the KSPCB Act and Factories Act.
  - ❖ Two layered walls with 6" gap shall be constructed around the DG.
  - ❖ The gap shall be filled with wood shavings or other acoustic materials.
  - ❖ Since the DG rooms are temporary in nature, the roof shall be of CGI sheets with adequate provision for taking the exhaust pipe through it.
  - ❖ The DG sets shall be provided with exhaust stacks of requisite height as per KSPCB Norms.
  - ❖ Periodic maintenance shall be carried out to minimize noise levels.
- Other Plant & Machinery and equipments which cannot be enclosed shall be periodically maintained to minimize noise levels.
- Maintenance of all company owned vehicles regularly.
- The noise levels of the DG set and various other noise generating equipments are measured and monitored periodically and recorded.
- Caution boards such as 'High Noise Area' shall be displayed at the required areas.
- Only such activity which does not produce much noise is carried out in the sites at nights.

### **In addition to the above steps the following precautionary measures shall be implemented:**

- Concerned personnel shall ensure that all the personnel working near the high noise areas, wear earmuffs/earplugs.
- Concerned personnel shall ensure that the earmuffs/earplugs are in good condition and the same shall be checked periodically for quality/damage.
- Entry of unauthorized personnel shall not be permitted into high noise areas.

## **CONTROL OF DUST AND AIR EMISSIONS**

### **PROCEDURE**

#### **12.3.1 Dust Control**

##### **The following are the sources of dust generation on site**

- Movement of vehicles
- Unloading of construction material like cement, sand and aggregate
- Concrete mixing etc.

##### **The following methods shall be adopted to prevent dust emission**

- Cement from stores shall be carried in trolleys to minimize the generation of dust.
- It is ensured that no hooks are used while shifting the cement bags.
- Loading and unloading area shall be located at a safe distance from the construction and office area where the chance of dust emissions is less.
- Loading and unloading areas shall be away from the edge of the site, ensuring that the dust particles do not affect the ecology surrounding the site.
- Dust generation during vehicular movement or due to any other activity in the construction site, shall be controlled by sprinkling of water.
- Personnel working in stores and in other places within the construction site, where there is more dust generation, shall wear dust masks and appropriate PPE, to reduce the risk.

#### **12.3.2 Smoke**

##### **The following are the sources of smoke generation on site**

- Emissions from DG
- Vehicles
- Diesel / Petrol Fuelled equipments

##### **Emission Control**

The following methods shall be adopted to minimize emission and to keep the emission under check:

- ❖ Ensure that the engine of the vehicle is switched off during loading and unloading operations.
- ❖ Emission certificates of all the vehicles entering the site are checked to ensure that the same are valid.



- ❖ The company vehicles are also checked for emission regularly to mitigate the air pollution due to high emission.
- ❖ All the P&M, equipments and vehicles are periodically maintained to minimize emissions which can lead to air pollution.
- ❖ The DG sets shall be provided with exhaust stacks of requisite height as per KSPCB Norms.

#### **12.4 WASTE MANAGEMENT IN SITES AND OFFICES**

##### **PROCEDURE**

- ❖ All the wastes generated in the departments / construction site as a result of various activities are identified in the Aspect – Impact Analysis Register.
- ❖ Any waste generated as a result of a new process or activity is appropriately identified.
- ❖ Areas where there is scope for improvement, are identified through Aspect Impact analysis and suitable objectives and targets made to improve these areas.
- ❖ Existing disposal methods are also reviewed from time to time.
- ❖ All personnel handling waste shall wear appropriate PPE like gloves, face mask and safety goggles.
- ❖ All wastes shall be kept in identified storage points and protected from rain before disposing it off properly.
- ❖ Wastes shall be stored in bins earmarked for that purpose. Color coding for bins is as follows: Red colored bins for hazardous wastes, Green colored bins for bio-degradable wastes, yellow colored bins for other types of wastes)

**The following are the procedures to be implemented by the respective department to address the handling, storage and disposal of wastes.**

##### **12.4.1 Used / waste oil**

**The used / waste oil shall be collected in a 200 liter container which shall be suitably marked. This shall be checked for any leakages prior to usage.**

- ❖ The same shall be disposed off to the authorized collecting agency.
- ❖ During storage and changing of oil, it shall be ensured that no spillage takes place by use of trays / troughs.

##### **12.4.2 Contaminated Earth**

- ❖ Contaminated earth due to any spill of FOL shall be collected in suitable containers.
- ❖ Till authorized recyclers are identified, these sealed containers shall be stored separately at the respective sites.

##### **12.4.3 Used cotton waste**

- ❖ Whenever cotton waste is used at the site, it shall not be thrown haphazardly.
- ❖ It shall be collected in a bin earmarked for the purpose.

- ❖ This shall also be disposed off through an authorized agency.

#### 12.4.4 Batteries

- ❖ Old batteries shall be collected at one place in the store of the site / department.
- ❖ These shall also be disposed off through the authorized dealer.

#### 12.4.5 Bio Medical Waste

- ❖ Used bandages, cotton, syringes, expired medicines and empty bottles, shall be collected in a bin earmarked for the purpose.
- ❖ These shall also be disposed off through an authorized agency.

#### 12.4.6 Empty Paint Drums

- ❖ Used Paint drums shall be stored separately in an area earmarked for the purpose.
- ❖ These shall be disposed off on frequently basis through an authorized agency.

#### 12.4.7 Printer Cartridges / Ribbons:

- ❖ These shall be collected at a central place in the office / site.
- ❖ These shall also be disposed off through authorized collecting agencies.

#### 12.4.8 Plastic Waste

- ❖ These shall be collected at a central place in the office / site.
- ❖ These shall also be disposed off through authorized recycling agencies.

### 12.5 WATER CONSERVATION PRACTICES

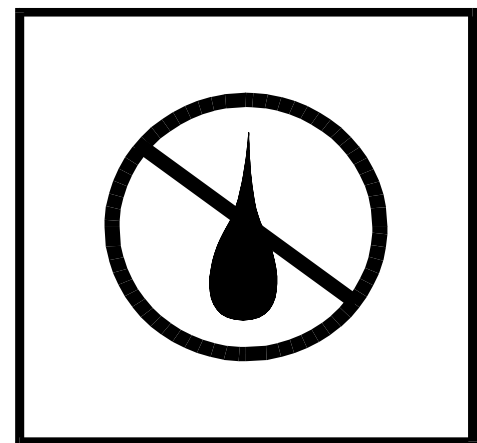
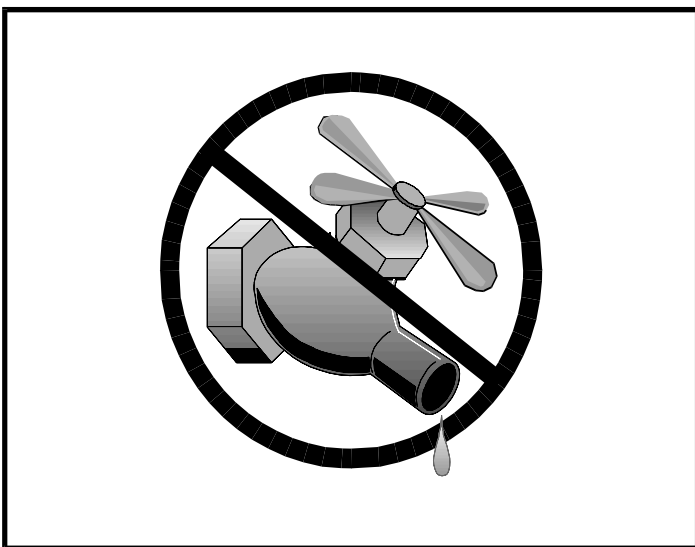

**Standard Symbol**

### **12.5.1 PROCEDURE**

- Keep water equipment in good working condition.
- Stabilize water truck filling area.
- Repair water leaks promptly.
- Vehicles and equipment washing on the construction site is discouraged.
- Direct construction water runoff to areas where it can infiltrate into the ground.

### **12.5.2 WATER CONSERVATION SHALL BE ACHIEVED THROUGH THE FOLLOWING METHODS:**

- Control of quantity of water consumption.
- Recycling waste water.
- Rain water harvesting.

### **12.5.3 Control of quantity of water consumption**

- The site in charge shall budget the quantity of water consumption for the site at the beginning of the project.
- The quantity of water consumption from various sources like bore wells, Municipal sources etc. shall be monitored and recorded.
- Wastage of water due to spillage / leakage shall be arrested.
- Inspection of storage tanks and pumping lines shall be carried out once in a fortnight for damage / leakage.
- Any person carrying water / manual pumping shall ensure proper handling to avoid spillage / leakage.

### **12.5.4 Recycling of waste water**

Waste water generated out of the following activities shall be recycled, where applicable

- Wash water from concrete mixers.
- Wash water from RMC mini batching plants (Onsite installations where available).
- Waste water from domestic use.

### **12.5.5 Water discharge control**

- The site shall ensure that the waste water passes through a STP before recycling.

- The solid waste generated during the STP operation shall be treated as per the solid waste management procedures.

## 12.6 SPILL PREVENTION AND CONTROL

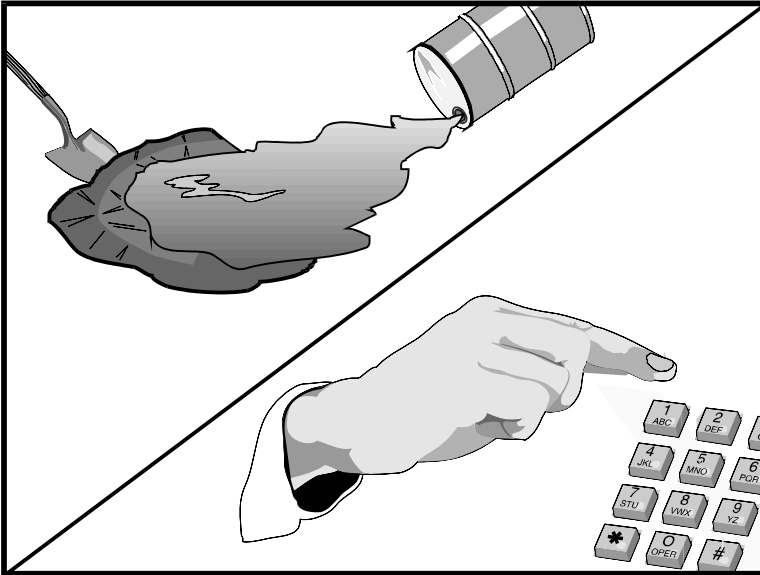

**Standard Symbol**

This procedure includes the steps to be taken to prevent land and water contamination due to spillage of fuel, oil, lubricants and paints during various operations. Spill control procedures are implemented anytime chemicals and/or hazardous substances are stored. Substances may include, but are not limited to:

Fuels, Lubricants, oil, paints, herbicides and fertilizers.

### 12.6.1 PROCEDURE

- The Project Head shall identify all the potential spillage and leakage points in his area of operation.
- At all the potential spillage / leakage points, arrangements like use of trays etc. are made for collection of diesel, oil etc. These contents are collected in designated containers and disposed through authorized agents.
- Contaminated materials, and recovered spill material that is no longer suitable for the intended purpose shall be stored and disposed through authorized agents.
- Spills shall not be buried or washed with water.
- Water used for cleaning and decontamination shall not be allowed to enter storm drains or watercourses and shall be collected and disposed off in accordance with the prevailing standards.
- Proper storage, clean-up and spill reporting instruction for hazardous materials stored or used on the project site shall be posted at all times in an open, conspicuous and accessible location.

### 12.6.2 Minor Spills

- Minor spills typically involve small quantities of oil, gasoline, paint, etc., which can be controlled by the first responder at the discovery of the spill.

- Use absorbent materials on small spills rather than hosing down or burying the spill.
- Remove the absorbent materials promptly and dispose of properly.
- The practice commonly followed for a minor spill is:
  - ✓ Contain the spread of the spill.
  - ✓ Recover spilled materials.
  - ✓ Clean the contaminated area and / or properly dispose of contaminated materials.

### **12.6.3 Semi-Significant Spills**

- Semi-significant spills still can be controlled by the first responder along with the aid of other personnel such as laborers and the foreman, etc. This response may require the cessation of all other activities.
- Clean up spills immediately.
- Notify the project head immediately.
- Contain spread of the spill.
- Contain the spill by encircling with absorbent materials and do not let the spill spread widely.
- If the spill occurs in dirt areas, immediately contain the spill by constructing an earthen dike. Dig up and properly dispose of contaminated soil.
- If the spill occurs during rain, cover spill with tarps or other material to prevent contaminating runoff.

### **12.6.4 Significant/Hazardous Spills**

- For significant or hazardous spills that cannot be controlled by personnel in the immediate vicinity, the following steps shall be taken:
  - ✓ Notify the Project Head immediately.
  - ✓ Notify the local authority. It is the contractor's responsibility to have all emergency phone numbers at the construction site.
  - ✓ The services of a spills contractor or a Haz-Mat team shall be obtained immediately. Construction personnel shall not attempt to clean up the spill until the appropriate and qualified staff has arrived at the job site.

## 12.7 SOLID WASTE MANAGEMENT

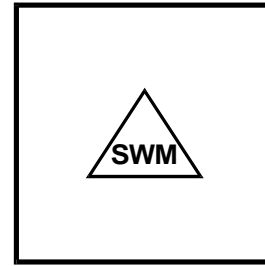
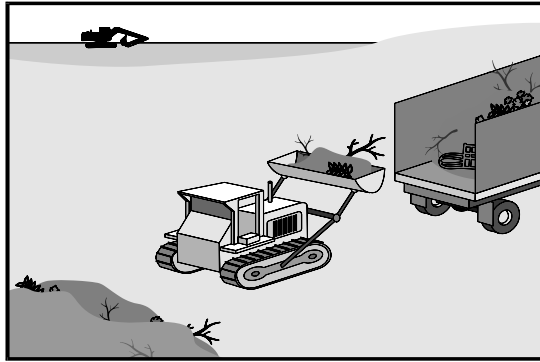

**Standard Symbol**

### 12.7.1 Definition of Solid Waste: Solid wastes include but are not limited to:

Construction wastes including brick, mortar, timber, steel and metal scraps, sawdust, pipe and electrical cuttings, non-hazardous equipment parts, materials used to transport and package construction materials.

Litter, including food containers, beverage cans, coffee cups, paper bags, plastic wrappers, and smoking materials, including litter generated by the public.

### 12.7.2 Waste Management Hierarchy

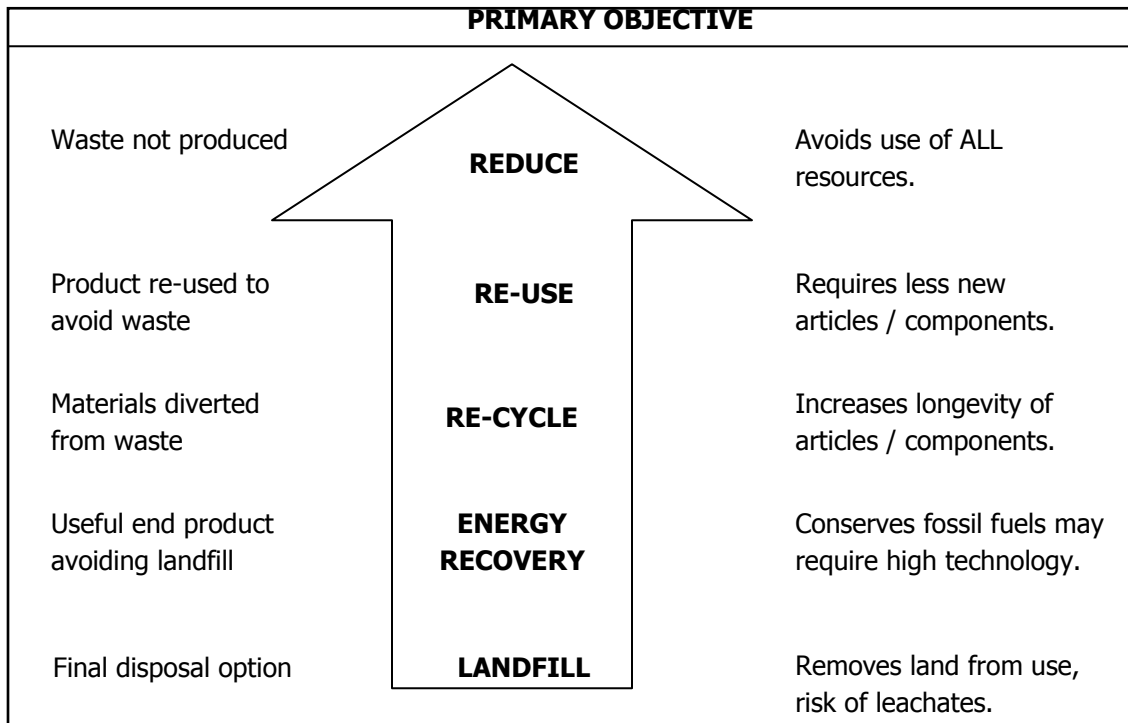



## Five steps in Waste Management

**Step 1:** Identify waste streams

**Step 2:** Categorize waste according to legal definitions and implement control regime that meets regulatory requirements

**Step 3:** Select the most efficient/ effective waste management option

**Step 4:** Prepare and implement a plan to manage the wastes produced, handled and stored on-site.

**Step 5:** Prepare and implement plan to manage the transfer of wastes off-site.

### 12.7.3 PROCEDURE

#### Collection, Storage, and Disposal

- Littering on the project site shall be prohibited. (Responsibility: Project Head)
- Dustbins of sufficient size and number shall be provided to contain the solid waste generated by the projects and offices and properly serviced. (Responsibility: Admin Department in case of offices and Project Head in case of sites)
- Trash cans shall be provided in the labour shed, canteen and at locations where workers assemble for lunch and break periods. (Responsibility: Admin Department in coordination with Projects)
- Construction debris and litter from work areas within the construction limits of the project site shall be collected and placed at a common collection area point (debris yard) that is accessible to a tractor cum trailer. Shift the debris on a daily basis.
- Collected litter and debris shall not be placed in or next to drain inlets, storm water drainage systems or watercourses.
- Solid waste storage areas shall be located at least 15 m (50 ft) from drainage facilities and watercourses and shall not be located in areas prone to flooding or pounding.
- Plan for additional trash containers during the demolition and finishing phase of construction.
- Construction waste shall be stored in a designated area approved by the Project Head.
- Segregate potentially hazardous waste from non-hazardous construction site waste. Also have separate trash cans for recyclable waste and bio-degradable wastes.
- Keep the site clean of litter debris.

- Make sure that toxic liquid wastes (e.g., used oils, solvents, and paints) and chemicals (e.g., acids, pesticides, additives, curing compounds) are not disposed of in trash cans designated for construction debris.
- Have hazardous waste hauled to an appropriate disposal and/or recycling facility.
- Salvage or recycle useful vegetation debris, packaging and/or surplus building materials when practical. Wood pallets, cardboard boxes, construction scraps etc. are some that could be recycled.
- The Project Head shall oversee and enforce proper solid waste management procedures and practices.

**In short the method to be adopted for disposal is as below:**

- Segregation at source.
- Collection and storage.
- Re use / Recycling.
- Disposal to the right source.

### 12.8 HAZARDOUS WASTE MANAGEMENT

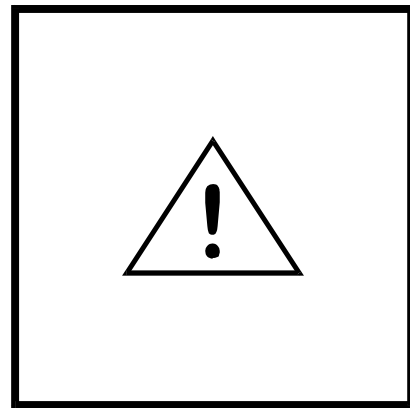
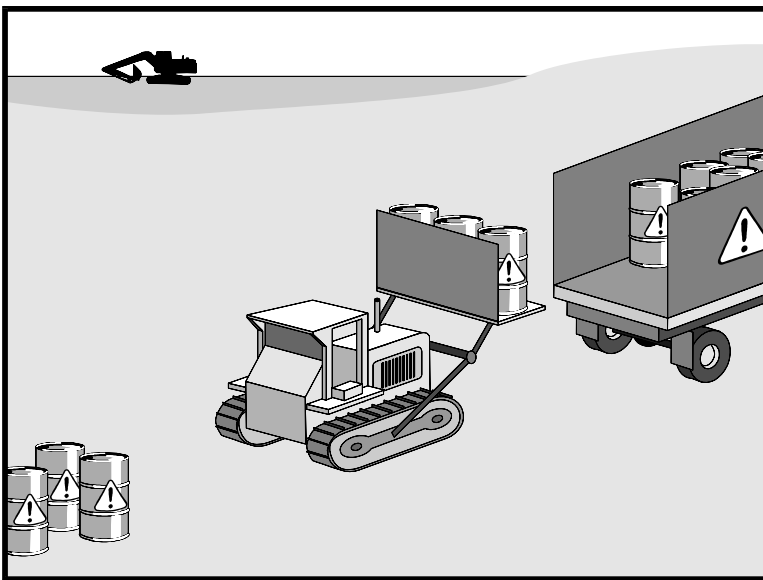

**Standard Symbol**

Hazardous waste management practices are implemented on construction projects that generate waste from the use of:

- Petroleum Products.
- Asphalt Products.
- Concrete.
- Pesticides.
- Acids.
- Paints.

- Solvents.
- Wood Preservatives.
- Chemical containers and cans.
- Glass.
- Plastic waste.
- Used cotton waste.

### **12.8.1 STORAGE PROCEDURES**

- All hazardous waste shall be stored, transported, and disposed off in accordance with the relevant standards.
- Storage facilities shall be equipped with adequate ventilation. (Responsibility: Project Head)
- Drums shall not be overfilled and wastes shall not be mixed.
- Paint brushes and equipment for water and oil based paints shall be cleaned within a contained area and shall not be allowed to contaminate site soils, watercourses or drainage systems. (Responsibility: Project Head)
- Waste paints, thinners, solvents, residues, and sludge that cannot be recycled or reused shall be disposed of as hazardous waste. (Responsibility: Project Head in coordination with Purchase Department)
- When thoroughly dry, latex paint and paint cans, used brushes, rags, absorbent materials, and drop cloths shall be disposed of as solid waste.
- Ensure that adequate hazardous waste storage volume is available.
- Ensure that hazardous waste collection containers are conveniently located.
- Hazardous waste storage areas on site should be away from storm drains or watercourses.
- Minimize production or generation of hazardous materials and hazardous waste on the job site.
- Segregate potentially hazardous waste from non-hazardous construction site debris.
- Keep liquid or semi-liquid hazardous waste in appropriate containers (closed drums or similar) and under cover.
- Do not allow potentially hazardous waste materials to accumulate on the ground.

### **12.8.2 DISPOSAL PROCEDURES**

- Waste shall be disposed of by a licensed hazardous waste transporter at an authorized and licensed disposal facility or recycling facility.
- Make sure that toxic liquid wastes (e.g., used oils, solvents, and paints) and chemicals (e.g., acids, pesticides, additives, curing compounds) are not disposed of in trash cans designated for solid waste construction debris.
- Recycle any useful material such as used oil or water-based paint when practical.

## 12.9 CONCRETE WASTE MANAGEMENT

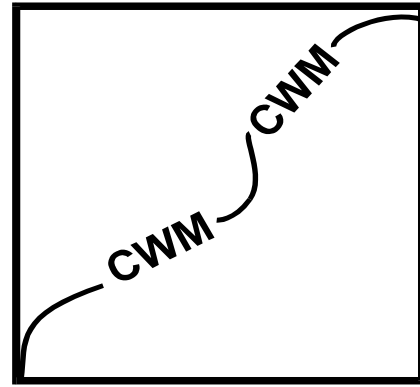
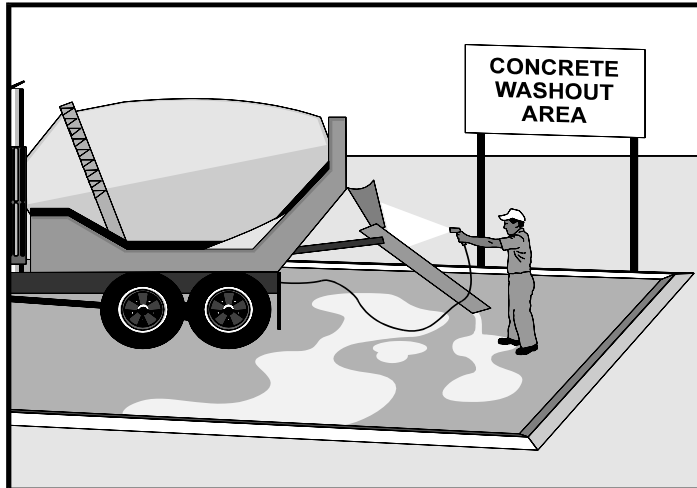

Standard Symbol

**Concrete waste management procedures and practices are implemented on construction projects,**

- Where concrete is used as a construction material.
- Where concrete dust and debris result from demolition activities.
- Where slurries containing Portland cement Concrete (PCC) is generated.
- Where concrete trucks, pumps and other concrete-coated equipment are washed on site.
- Where concrete mixers and mini batching plants exist.

### PROCEDURE

#### 12.9.1 Concrete Slurry Wastes

- PCC waste shall not be allowed to enter storm drains or watercourses.
- PCC waste shall be collected and hardened PCC properly disposed off in conformance with relevant standards.
- A foreman and/or construction supervisor shall monitor onsite concrete working tasks to ensure proper methods are implemented.

#### 12.9.2 Onsite Temporary Concrete Washout Facility Procedures

- Temporary concrete washout facilities shall be identified within the site premises.
- Temporary concrete washout facilities shall be located a minimum of 15 m (50 ft) from storm drain inlets, open drainage facilities, and watercourses, unless determined infeasible by the Project Head.
- Temporary concrete washout facilities shall be constructed and maintained in sufficient size to contain all liquid and concrete waste generated by washout operations.

- Wash concrete from mixer truck chutes, concrete pumps and concrete mixers only at the approved concrete washout facility.
- Pump excess concrete in concrete pump bin back into concrete mixer truck.
- Once concrete wastes are washed into the designated area and allowed to harden, the concrete shall be broken up, removed, and disposed off in conformance with the applicable standards.

### **12.10 SANITARY/SEPTIC WASTE MANAGEMENT**

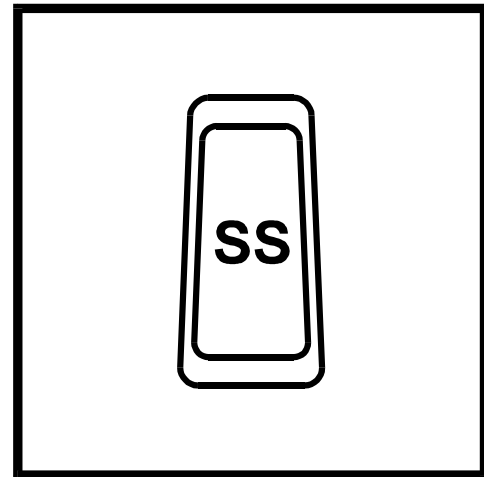
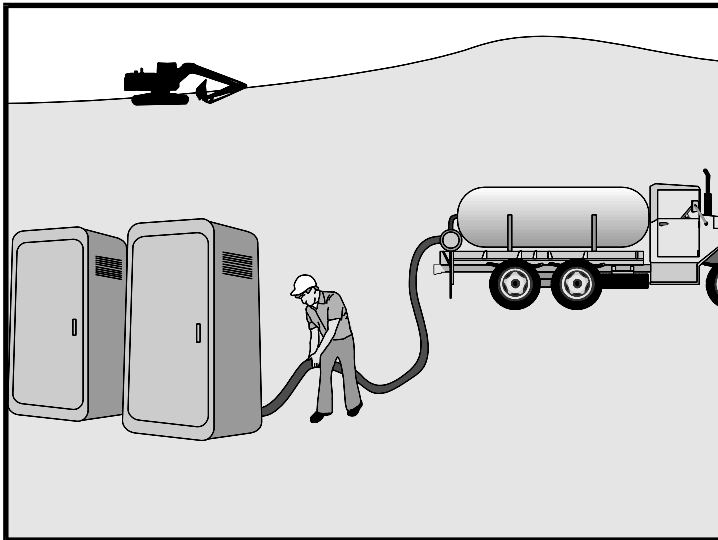

**Standard Symbol**

### **STORAGE AND DISPOSAL PROCEDURES**

- Temporary sanitary facilities shall be located away from drainage facilities, watercourses.
- Sanitary and septic systems that discharge directly into sanitary sewer systems, where permissible, shall comply with the local health agency requirements.
- If using an onsite disposal systems, such as a septic system, comply with local health agency requirements.
- Properly connect temporary sanitary facilities that discharge to the sanitary sewer system to avoid illicit discharges.
- Ensure that sanitary / septic facilities are maintained in good working order.
- Use only reputable, licensed sanitary / septic waste haulers.

## **12.11 STP SLUDGE DISPOSAL, GARBAGE COLLECTION AND DISPOSAL.**

### **12.11.1 SCOPE**

- Sludge collection, process to convert the sludge as manure and its usage in green belt.
- Collection, segregation and disposal of garbage from apartments.

### **PROCEDURE**

#### **12.11.2 SEWAGE TREATMENT PLANT SLUDGE**

- Identify the location for dumping the sewage treatment plant sludge in green belt area.
- Make pits of sufficient size and capacity to fill the sludge.
- Unload the sludge into the pit.
- Spray urea / compost over that and cover the pit with soil.
- After six months, the sludge will be converted to manure and is ready for green belt use.
- Use it for green belt. The pit shall be used for next fill.

#### **12.11.3 GARBAGE COLLECTION AND DISPOSAL**

- Collection of garbage from the houses daily.
- Segregation of recyclable wastes, biodegradable wastes and other non-recyclable wastes.
- Make suitable arrangements with Public Garbage Collection System to collect garbage in a periodic manner.

#### **12.11.4 RECYCLING AND REUSE OPTION FOR HOUSEHOLD WASTE**

<b>Waste Category</b>	<b>Recycle/Reuse options</b>
'Green waste' (grass cuttings, etc.)	Composting
Paper and cardboard waste	Repel for low grade board and paper
Household metal goods	Re-smelt
Glass bottles	Re-melt and recast
Residual waste	Landfill



## 12.12 DISPOSAL OF EMPTY CONTAINERS

### SCOPE

- ❖ Detoxification of Empty Containers / Drums and Disposal or reuse.
- ❖ Eliminate Land and Water Contamination by unused hazardous substance left in the empty drums / containers.

### PROCEDURE

- ❖ The existing material identification markings and letterings in all the sides of the empty containers are to be struck off with 'X' mark using paint / sticker / Permanent Marker.
- ❖ Empty liquid containers is either to be used after visually checking for leaks for storing waste substance or moved to scrap yard.
- ❖ Empty containers / bags can be sent back without washing to supplier / dealer where agreed mutually.
- ❖ Unless specified otherwise in any other operational control procedure, the empty containers are to be cleaned with water / suitable chemical in the area where provision for sending effluent for treatment is available.
- ❖ Washed containers / bags can be sold to any Scrap dealers.
- ❖ **Safety gadgets:** Use Rubber or PVC gloves and Shoes while washing empty containers.

### **13 HEALTH & HYGIENE ARRANGEMENT AT SITE**















Contractor should ensure that basic hygienic arrangement provided at site sufficient to the people employed at site. Minimum arrangements required under BOCW Rules 2006 should be made by the contractor.

#### **13.1 Site Arrangement**

- Latrine and urinal arrangements – It should be separate for man & woman workers. It should be sufficient in numbers to accommodate total persons at site.
- Canteen or proper arrangement where workers can take their food.
- Washing Facilities ---In every construction site adequate and suitable facilities for washing should be provided and maintained for the use of workers employed. Facilities should be conveniently accessible and should be kept in clean and hygienic condition.
- Drinking water facility should be arranged for the drinking water need of the workers employed at site.
- Provision of shelter during rest - Suitable sheds two for meals and other two for rest separately should be provided for the use of men and women labour.

## 14. PERSONAL PROTECTIVE EQUIPMENT (PPE)

- Personal Protective equipment is barrier between the person and the hazard. These provide adequate protection, when selected properly and used and maintained in accordance with the manufacturers guidelines. A proper hazard assessment therefore is a must before selecting/stipulating a PPE.
- Personal protective equipment is not a foolproof safety system and therefore, more emphasis should be given on engineering & administrative controls to eliminate or minimize the hazards. All efforts must be made to free from trip hazards.
- Effort to minimize the hazard must be adequate & appropriate. All necessary personal protective equipment must be Indian standard as a minimum & approved by Site HSE Staff should be available for use of persons employed on the site and maintained in a condition suitable for immediate use, and the contractor should take adequate steps to ensure proper use of equipment.
- All contractor workers (all persons hired by contractor/subcontractor) should wear minimum PPE that are Safety Helmet, Safety Shoes and Safety Reflective Jacket & Safety Glass without fail while working at construction site.
- Workers should be trained in proper use of PPEs. They should be taught pre-use inspection, storage & maintenance of PPEs.
- Contactor should maintain PPE store at construction site. Sufficient stock of PPE should always be maintained at site. Safety Steward/Supervisor should ensure that right type PPE issued to worker according the need of protection against the hazard.

		PERSONNEL PROTECTIVE EQUIPMENTS (PPEs) REQUIREMENT													
PPEs															
All Members		✓					✓						✓		
Type of Work & Requirement Of PPEs															
1	Earth Excavation	✓					✓						✓		✓
2	Shuttering (Form Work)	✓					✓	✓					✓		✓
3	Concrete Works	✓					✓			✓			✓	✓	✓
4	Welding Works	✓	✓		✓	✓	✓		✓				✓		✓
5	Gas Cutting Works	✓	✓				✓	✓	✓				✓		✓
6	Drilling Operation	✓	✓	✓			✓						✓		✓
7	Grinding Operation	✓	✓	✓	✓		✓	✓					✓		✓
8	Metal Cutting with machine	✓	✓	✓			✓	✓					✓		✓
9	Sheet Metal Work	✓					✓	✓					✓		✓
10	Machine unpacking (working at height)	✓					✓	✓				✓	✓		✓
11	Machine Shifting	✓					✓	✓				✓	✓		✓
12	Machine installation	✓	✓*				✓	✓					✓		✓
13	Rigging (Heavy Material Handling)	✓					✓	✓					✓		✓
14	Height Work	✓					✓	✓				✓	✓		✓
15	Chipping Works with power machine	✓	✓	✓	✓		✓	✓					✓		✓
16	Operators & Signal Man	✓			✓		✓						✓		

Example

## **Non Respiratory Personal Protective equipment**

### **1. Head Protection**

The personal protective equipment available for the protection of head is the safety helmet or hardhat. It is primarily designed to protect the worker's head from knock caused by impact, falling objects and even electricity. The brim of the helmet offers protection to the eyes and face.

Contractor should ensure that all workers entering in SITE construction site wear safety helmet without fail. The helmet should be ISI marked and should be provided by the contractor to people working at construction site.

### **2. Eye and face protection**

Suitable goggles or effective screen should be provided for the protection of eyes of persons employed in the process, which involves the following activities:-

- Dry grinding of metals by a revolving wheel or disc driven by mechanical power
- External or internal turning of non-ferrous metals.
- Welding or cutting of metal by means of an electrical, oxy-acetylene or similar process
- Breaking or dressing of stone, concrete.
- Handling and working with substances of a corrosive nature such as acids, alkalis, chemicals and removing agents
- Blasting work where grit, high-pressure water jets or other materials are used for cleaning and removing rust, scale, paint, etc.
- Any work where paints, paint compounds and chemicals are applied on the surface by means of spraying/brushing.
- Any other work as suggested by SITE representative

Note: Any person assisting or in the vicinity of the above-said processes, are also required to wear eye and face protection.

### **3 Hand and arm protection**

Accident statistics reveal that the fingers and hands are the most frequently injured parts of the body. Every building worker engaged in handling sharp objects or materials which may cause hand injury. In order to avoid accidents to fingers and hands should be provided with suitable hand-gloves by the contractor, in accordance with the SAFETY standards. The employees should wear protective equipment like gloves, gauntlets, hand pads, etc. The selection of gloves should depend on the nature of work and the risk involved.

Competent person should ensure that appropriate hand gloves issued to people which give protection against the hazard, which he/she is likely to expose. People should also train about different type of hand gloves, hazard against which is gives protection and proper use of the hand gloves.

#### **4 Foot protection**

Injuries to the foot are mainly caused by the falling of materials while handling or by the foot striking against materials or objects. Safety shoes with steel toecaps protect the toes from falling objects and striking against objects. The steel inner sole affords protection against protruding nails or sharp objects. In addition to the use of safety shoes, foot gaiters should be worn while carrying out welding and cutting operations.

Every building worker required to work in water or in wet concrete or in other similar work at a building or other construction work, should be provided with suitable waterproof boots by the contractor.

#### **5 Body Protection**

Workers likely to be exposed to corrosive or other harmful substance should wear appropriate body protection. Every building worker required using or handling of alkalis, acid or other similar corrosive substances at a building or other construction work should be provided with appropriate protective equipment by the contractor, in accordance with the SAFETY.

Every building worker required to work in rain or in similar wet condition at building or other construction work, should be provided with waterproof coat with hat by the employer.

#### **6 Protection against falling from heights**

Where any person is required or allowed to work at a place from which he may be liable to fall through a distance of 6 feet or more, he should be provided with full body harness system. This is the secondary safety measure. It should not be taken as substitute of engineering control like proper working platform with railing, guardrails, etc.

Full body harness should be ISI marked as a minimum and confirm Bureau Indian Standards requirements. Test certificate issued by the manufacturer should be maintained at site.

A competent person should inspect full body harness system at least once in every 3 months and the record of inspections should be maintained. Every worker is to be trained regarding proper use of full body harness and condition checks of it. Person working at height should be instructed to do condition check of full body harness prior to use. Use full body harness with double lifeline should be encouraged while working on scaffolding, roof, edge of building, etc.

**Safety net and its use:** Every safety net should be of adequate strength, made of sound Material and should be suitable for use and conforms to the safety standard;

Responsible person for maintenance of safety nets and its use should ensure safe fixing of safety nets and provide safety nets with suitable and sufficient anchorage so that the purpose for which safety net is intended for use, is served.

## 7 Hearing Protection

To protect the ear (hearing ability) from industrial noise, the following types of protective devices should be used:-

### a) Earplug

The earplugs are usually made of soft rubber or PVC materials. The noise reduction obtainable by the use of ear plugs ranges from 15 dB (A) to 20 dB (A), provided it is used as per manufacturer's recommendation.

### b) Ear Muff

The effectiveness of the earmuff depends upon the size, shape, seal materials and the type of suspension used. Earmuff gives a better protection than earplug. The noise reduction obtainable by the use of earmuffs ranges from 30dB (A) to 40dB (A), provided it is used as per manufacturer's recommendation.

The contractor should ensure that all people who are exposed to noise should be provided with either earplug or earmuff and ensure its uses by people at work.

## Respiratory Personal Protective Equipment

When the working atmosphere is contaminated by dust, fumes and gases, suitable respiratory equipment should be used. There are number of respiratory protective equipment available for various types of operations carried out. The selection of respiratory equipment should be based on the nature of contaminant, the period for which the protection is required, concentration of the contaminant and the restriction of movement in the work area.

### ➤ Dust Respirator

Dust respirator should be used for protection against dust particles in the air. It is usually attached to half-face mask, containing filter paper or cotton, which screens fine particles of dust from the inhaled air. These dust respirators should not be used in an area where oxygen deficiency is noticed, or toxic gas or vapour present.

## Safety Signs & Posters

Safety signs & Posters should be displayed at conspicuous locations to make people aware about particular hazard. Safety signs used in the Premises should be in English, Hindi, Local language or in the language which is understood by maximum number of workers.

### (i) General Safety Signs

- Warning Signs
- Mandatory Signs
- Prohibition Signs



- Safe Condition Signs
- Fire Fighting Equipment Signs
- Supplementary Safety Signs

**(ii) Work Process Safety Signs**

- Hot-work in progress
- Testing of heating coils in progress
- Dismantling of pipelines/valves in progress
- Chemical cleaning in progress
- Transferring of fuel oil in progress
- Fuel vent pipe
- Painting in progress
- Radiography work in progress
- Grit blasting in progress
- Beware! Wire across road
- Fit for entry

## 15. FIRST AID CENTRE & EMERGENCY MEDICAL FACILITIES

### Introduction

First aid is necessary to prevent and treat sudden illness or accidental injury. The primary objective of first aid is to save lives by making the victim alive till proper medical attention is achieved

- Any building worker who is employed for a work involving risk or hazards should be medically examined at intervals as per the direction of the competent person. Ex:-Vertigo test for workers working at height, etc.,
- Every operator of a crane, winch or other lifting appliance, transport equipment or vehicle, should be medically examined before employing operator and again periodically, at intervals as the competent person may direct.
- The medical examination should be conducted as per the stipulations and should be conducted by medical officers or at hospitals, which are approved by the State Government for the purpose.
- The record of the medical examination of all building worker should be maintained in a register of prescribed format. Register should be made available in the site.

Occupational Health Centre (First Aid Centre) should be provided at site to take care of first aid injury. All necessary medicines and other aids should be available as per the BOCW Requirement. First Aid Centre should be maintained by trained and qualified first aider/s.

Contractor should provide ambulance van at site to take care of any medical emergency at site. The ambulance van should be equipped with necessary emergency medical equipment.

Stretcher and other emergency rescue equipment should be available at site.

#### **This objective is achieved with the following:**

- Preventing heavy blood loss.
- Maintaining breathing.
- Preventing further injury.

Preventing shock People who provide first aid must remember the following:

- Avoid panic.
- Inspire confidence.
- Do only what is necessary until professional help is obtained.
- Do not make trial on the victim.

#### **First Aid Kits**

A good First Aid Kit should be checked and restocked periodically and shall always contain the following items:

- Sterile adhesive bandages in assorted sizes.
- Sterile gauze pads in assorted sizes.
- Hypoallergenic adhesive tape.
- Scissors.
- Needle.
- Bandage.
- Moistened towelettes.
- Antiseptic.

- Thermometer.
- Tongue blades.
- Splints in assorted sizes.
- Petroleum jelly.
- Assorted sizes of safety pins.
- Anti-bacterial soap.
- Antibiotic ointment.
- Latex gloves and face mask.

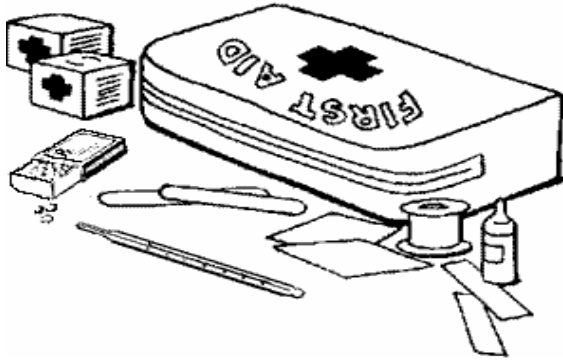

### ***Injuries and first aid:***

#### ***Bleeding (External)***

Most bleeding injuries are minor; however, heavy external bleeding can cause death in three to five minutes. In addition to the procedures for initial first aid, follow these steps for external bleeding:

- Using a sterile dressing, clean cloths, or other material, apply pressure directly over the wound.
- Direct contact with a victim's blood may expose the first aider to various communicable diseases. Always wear plastic gloves when assisting a bleeding victim.
- If possible, elevate the bleeding area. Otherwise, lay the victim flat, and elevate the legs.
- Keep the victims lying down
- Do not release pressure or lift the bandage until bleeding is stopped.

#### ***Burns***

Thermal and chemical burns require immediate attention. In addition to the Procedures for initial first aid follow these steps for thermal burns:

#### **For first and second degree burns:**

- Pour ordinary water to the burnt area or apply ice packs.
- Cover the burnt area with a clean cloth.
- Do not apply butter, oil, or cream to a burn.

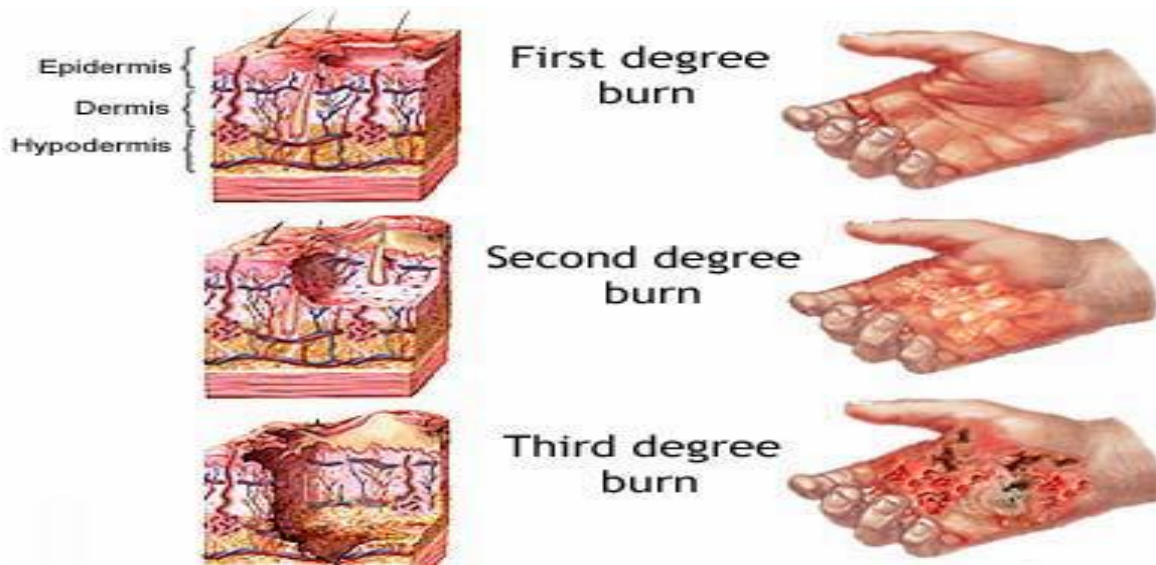

**For serious burns** (e.g., large area burns and charred skin):

- Remove clothing from the injured area.
- Carefully cut around clothing that adheres to the skin.
- Place an approved burn blanket or the cleanest available cloth over the entire burn area.
- If the victim is conscious, provide nonalcoholic fluids.

### ***Chemical Splashes***

Chemical splashes on the skin require immediate attention. Follow these steps:

- Go to emergency shower or sink.
- Remove clothing.
- Wash with water thoroughly for minimum of 15 minutes.
- Seek medical attention.

### ***Eye Injury***

- If hazardous liquid, particles, or gas irritate a person's eye, flush the eye with water for at least 15 minutes.
- Use an eye wash station, sink, or water fountain.
- Seek assistance from a physician, as necessary.
- If a foreign object (e.g., glass, pencil lead, etc.) is embedded in the eye, place a plastic cup or gauze over the affected eye.
- This will keep the eye from moving and inflicting further damage. Seek assistance from a physician immediately.

### ***Insect Bites***

- Call Medical Service or a physician whenever someone suffers multiple stings (or suffers adverse effects from a single sting) from wasps, bees, fire ants, or other stinging insects.
- For a single insect sting, remove the stinger.



- People who are extremely allergic to certain insect bites should carry appropriate medication and inform others of their allergy.

### Electric Shock:

- In the case of shock from portable electric tools, the victim should be freed by turning off the supply switch or by removing the plug.
- Other persons arriving on the scene must be clearly warned not to touch the suspected equipment until it is de-energized.

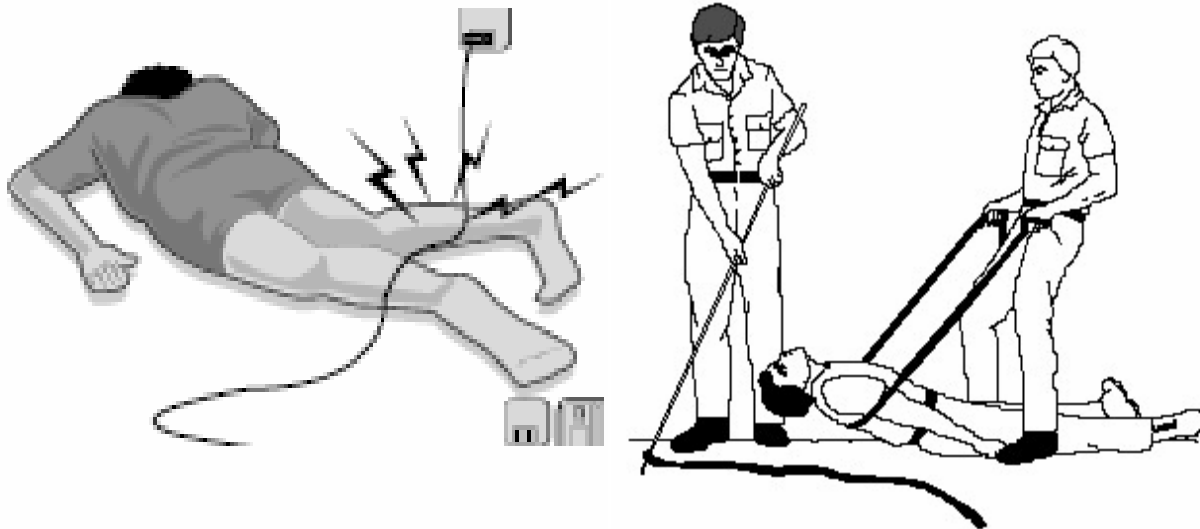

- The injured person shall be pulled free of contact with stationary equipment if the equipment cannot be quickly de-energized.
- This can be done quickly and easily by carefully applying the following procedures:
- Protect yourself with dry insulating material.
- Use a dry board, belt, clothing, or other available nonconductive material to free the victim from electrical contact.
- Do NOT touch the victim until the source of electricity has been removed.
- Once the victim has been removed from the electrical source, it should be determined whether the person is breathing.
- If the person is not breathing, a method of artificial respiration is used.

### Follow these steps to assist shock victims:

- Keep the victims lying down.
- Maintain an open airway. If the victim vomits, turn the head sideways and the chin downward.
- Elevate the victim's legs.
- Keep the victim warm.
- Reassure the victim.
- Call for emergency medical service.
- **Snake Bites**

If a snake bite occurs, follow these steps:

- Apply a constricting bandage between the wound and the heart.
- If possible, call emergency medical service.
- Transport the victim to the nearest hospital immediately.
- If necessary and possible, carry the victim to transportation.
- Do not let the victim walk.

If you cannot obtain medical attention:

- Do not make any incisions or suck out the poison.
- Do not cool the bitten area.
- Every fifteen minutes, loosen the constricting bandage for a few seconds and then reapply it.

### Cuts & Wounds:

- Flush clean water over the cut or wound, and then gently pad it dry with a short cotton swab or a clean tissue.
- Position a piece of short gauze over the wound as a temporary covering.

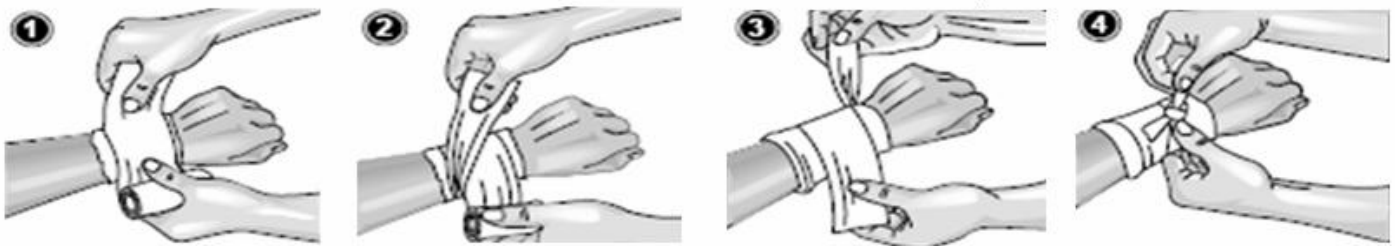

- Use a piece of cotton wool that has been dipped in water and soapy water to clean the skin surrounding the wound. Wipe away from the wound.
- Examine the wound; if it contains foreign particles, gently remove them with tweezers.
- If larger objects are embedded in the wound, do not attempt to take them out by yourself; take medical attention.
- If the wound is just a small cut, cover it with a plaster.
- Cover larger cuts with a sterile dressing and keep it in the position with a bandage; keep the wound covered until it is closed up.

## **16. CONSTRUCTION HEALTH & SAFETY REGULATIONS, CODES & BEST PRACTICES**

In addition to the requirement, the work shall be undertaken in accordance with all applicable legislation and Indian statutory requirement listed below but not limiting to:

1. Factories act 1948 & Karnataka factory rules 1969
2. Building and other construction workers Regulation of employment & Conditions of Service) Karnataka Rules, 2006 (Respective states have to refer to their State Rules).
3. Indian electricity act 2003 and rules 1956
4. National building code, 2005
5. The petroleum act, 1934 & rules 1976
6. Gas cylinder rules, 2003
7. Indian explosive act, 1934 along with the explosive substance act 1908 and explosive rules 1983
8. Child labour (Prohibition & Regulations) Act, 1986 and Rules 1950
9. Environment Protection Act, 1986 and Rules 1986
10. Air (Prevention and Control of pollution) Act, 1974
11. The Noise Pollution (Regulation & Control) Rules, 2000
12. Notification on Control of Noise from Diesel Generator (DG) sets, 2002
13. Manufacture, Storage & Import of hazardous Chemicals Rules, 1989
14. The Hazardous Waste Management Rules 1989 (as amended in 1999)
15. Batteries (Management and Handling) Rules.

### **Bureau of Indian Standards related to Health & Safety**

Standards to be followed included but not limited to following -

- IS: 3696 (Part I) -1966 Safety code for scaffolds and ladders: Part I Scaffolds
- IS: 3696 (Part II)-1966 Safety code for scaffolds and ladders: Part II Ladders
- IS: 3764-1966 Safety code for excavation work
- IS: 4014 (Part – I) Code of Practice for Steel Tubular Scaffolding
- IS: 4082-1977 Recommendations on stacking and storage of construction materials at site (first revision)
- IS: 4130-1976 Safety code for demolition of building (first revision)
- IS: 4912-1978 Safety requirements for floor and wall openings, railings and toe boards (first revision)
- IS: 5121-1969 Safety code for piling and other deep foundations
- IS: 5916-1970 Safety code constructions involving use of hot bituminous materials













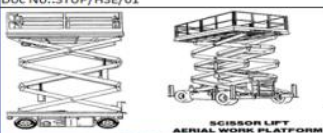

- IS: 7205-1974 Safety code for erection of structural steel work
- IS: 7969-1975 Safety code for handling and storage of building materials
- IS: 8989-1978 Safety code for erection of concrete framed structures.

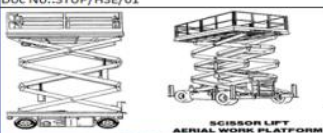
Note: 1. For all standards latest version should be taken into consideration.

2. Other relevant bureau of Indian Standard or any international standards should be complied as and when required.

## 17. CHECK SHEETS

The following are some of the check sheets / formats to be followed and to be submitted along with Request For Inspection (RFI) for the each and every activity wherever and whenever required and also at regular intervals to be specified by contractor and approved by the Competent Authority for each project separately. Each sheet shall have signatures of contractor's representatives and Engineer / Engineer's representative and all these sheets shall be submitted as part of Monthly Progress Report (MPR) by the Contractor.

Check List for Aerial / Scissor Lifter					Check List for Bar Bending Machine																																																																																																																																		
Contractor Name: Doc No.:STUP/HSE/01		Date:					Contractor Name- Doc No.:STUP/HSE/02																																																																																																																																
 SCISSOR LIFT AERIAL WORK PLATFORM		SL. NO	CHECK ITEMS	PHOTOS	Y/N																																																																																																																																		
		1	Level adjustment is in good working condition		Mon Tue Wed Thu Fri Sat Sun	<table border="1"> <thead> <tr> <th>SL NO</th> <th>DESCRIPTION</th> <th>Day</th> <th>Day-1 Mon</th> <th>Day-2 Tue</th> <th>Day-3 Wed</th> <th>Day-4 Thu</th> <th>Day-5 Fri</th> <th>Day-6 Sat</th> <th>Day-7 Sun</th> </tr> </thead> <tbody> <tr><td>1</td><td>Erected in a firm base concrete platform.</td><td></td><td></td><td></td><td></td><td></td><td></td><td></td><td></td></tr> <tr><td>2</td><td>Machine is grouted properly/ Base wheel stopper provided</td><td></td><td></td><td></td><td></td><td></td><td></td><td></td><td></td></tr> <tr><td>3</td><td>Body Earthing is provided</td><td></td><td></td><td></td><td></td><td></td><td></td><td></td><td></td></tr> <tr><td>4</td><td>D.B box connected with the machine is equipped with MCB and ELCB.</td><td></td><td></td><td></td><td></td><td></td><td></td><td></td><td></td></tr> <tr><td>5</td><td>Emergency switch is available in working condition ( Front side and back side of the m/c)</td><td></td><td></td><td></td><td></td><td></td><td></td><td></td><td></td></tr> <tr><td>6</td><td>Power on &amp; off switch with indicator light are available in working condition.</td><td></td><td></td><td></td><td></td><td></td><td></td><td></td><td></td></tr> <tr><td>7</td><td>Belt and other internal moving parts are covered/Guarded.</td><td></td><td></td><td></td><td></td><td></td><td></td><td></td><td></td></tr> <tr><td>8</td><td>No oil leakage</td><td></td><td></td><td></td><td></td><td></td><td></td><td></td><td></td></tr> <tr><td>9</td><td>Both side hand guard is available.</td><td></td><td></td><td></td><td></td><td></td><td></td><td></td><td></td></tr> <tr><td>10</td><td>Limit switch (Both Side, below the job plate) are in working condition</td><td></td><td></td><td></td><td></td><td></td><td></td><td></td><td></td></tr> <tr><td>11</td><td>Availability of standard limit switch pin (Usage of nail &amp; other material is N.G)</td><td></td><td></td><td></td><td></td><td></td><td></td><td></td><td></td></tr> </tbody> </table>										SL NO	DESCRIPTION	Day	Day-1 Mon	Day-2 Tue	Day-3 Wed	Day-4 Thu	Day-5 Fri	Day-6 Sat	Day-7 Sun	1	Erected in a firm base concrete platform.									2	Machine is grouted properly/ Base wheel stopper provided									3	Body Earthing is provided									4	D.B box connected with the machine is equipped with MCB and ELCB.									5	Emergency switch is available in working condition ( Front side and back side of the m/c)									6	Power on & off switch with indicator light are available in working condition.									7	Belt and other internal moving parts are covered/Guarded.									8	No oil leakage									9	Both side hand guard is available.									10	Limit switch (Both Side, below the job plate) are in working condition									11	Availability of standard limit switch pin (Usage of nail & other material is N.G)								
SL NO	DESCRIPTION	Day	Day-1 Mon	Day-2 Tue	Day-3 Wed	Day-4 Thu	Day-5 Fri	Day-6 Sat	Day-7 Sun																																																																																																																														
1	Erected in a firm base concrete platform.																																																																																																																																						
2	Machine is grouted properly/ Base wheel stopper provided																																																																																																																																						
3	Body Earthing is provided																																																																																																																																						
4	D.B box connected with the machine is equipped with MCB and ELCB.																																																																																																																																						
5	Emergency switch is available in working condition ( Front side and back side of the m/c)																																																																																																																																						
6	Power on & off switch with indicator light are available in working condition.																																																																																																																																						
7	Belt and other internal moving parts are covered/Guarded.																																																																																																																																						
8	No oil leakage																																																																																																																																						
9	Both side hand guard is available.																																																																																																																																						
10	Limit switch (Both Side, below the job plate) are in working condition																																																																																																																																						
11	Availability of standard limit switch pin (Usage of nail & other material is N.G)																																																																																																																																						
		2	Access ladder to the platform is with out any defects, missing rungs.		Mon Tue Wed Thu Fri Sat Sun																																																																																																																																		
		3	Availability of limit switch for the platform extension		Mon Tue Wed Thu Fri Sat Sun																																																																																																																																		
SL. No	CHECK ITEMS	PHOTO	Y/N	 SCISSOR LIFT AERIAL WORK PLATFORM																																																																																																																																			
8	Scissor lifter working platform is provided with hand rail and mid rail		Mon Tue Wed Thu Fri Sat Sun																																																																																																																																				
9	Availability of four outrigger in four sides (Depends on type of equipment)		Mon Tue Wed Thu Fri Sat Sun																																																																																																																																				
10	All wheels are in good working condition		Mon Tue Wed Thu Fri Sat Sun																																																																																																																																				
11	All hazards signs and operating instruction displayed.		Mon Tue Wed Thu Fri Sat Sun																																																																																																																																				

Page 1

### Check List for Chipping & Concrete Drilling Machine



Contractor Name: \_\_\_\_\_ Doc No.: STUP/HSE/03

SL NO	DESCRIPTION	Day	D1	D2	D3	D4	D5	D6	D7
			MON	TUE	WED	THU	FRI	SAT	SUN
1	Presence of back handle gripper & its condition. Wear, Damages								
2	Presence of rear handle gripper & its condition. Wear, (Damages)								
3	Working condition of ON/OFF switch.								
4	Presence of cable Gland.								
5	Industrial type plug for power tapping cable of chipping machine.								
6	Presence of damages in the entire body (Cracks)								
7	Electrical cable condition (Damages)								

### Check List for Mobile Crane

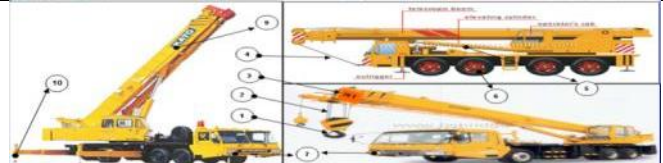

SL NO	CHECK ITEM	PHOTOS	Y/N	SL NO	CHECK ITEMS	PHOTOS	Y/N
1	Safety latch in hook.			2	Holt limit switch (Or presence of plate).		
3	SWL marked in crane.			4	Wire rope and slings free from tolerable damage( No kinks, broken wires more than 10% is N.G)		
5	No oil leak in hydraulic parts (piston drums).			6	No Damage in Tire ( Crack, cut, air pressure etc).		
7	Head and tail lamps (for night working).			8	Front and reverse horn.		
9	Boom structure condition while full expansion (damage, crack and jamming while extending).			10	Fire extinguisher in operator cabin.		
11	Four outrigger are in good working condition						
11. DOCUMENTS				11. DOCUMENTS			
11.A	Third party certificate(Form 32)			11.C	Operator license (heavy duty).		
11.B	Vehicle valid insurance			11.D	Road tax		

### Check Sheet for Electrical Panel Board

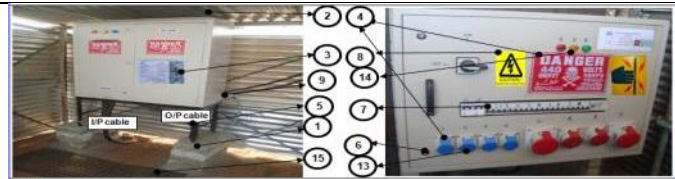

DATE: \_\_\_\_\_

SL NO	CHECK ITEM	PHOTOS	Y/N	SL NO	CHECK ITEM	PHOTOS	Y/N
1	Firm Base with grouting & Easily accessible panel (height of the leg is equal to 1m)			2	The Housing & connections of D.B is weather proof. (minimum of IP 44 type)		
3	Authorized Operator Name Photo, Contact No. on DB panel (Confirmation)			4	Visualization of voltage, current and type of tools to be used in the socket & Panel.		
5	Identification of input and output cables			8	Safety sign / isolate flammable Fire Hazard		
7	Separate MCB for every socket			10	Separate ELCB with tripping current of 30 mA & in working condition.		
9	Double Earthing System of MCB / DB panel with Std earthing pit			12	Presence & Condition of Bus bar/ Terminal		
11	Hylam sheet to be provided over live bus bars			14	Color coding to be followed (RYB) for all cables/wires		
13	Condition of Cable, Power Socket and Plug without damage			16	Plug-Socket should be Industrial type (IP 44 type)		
15	Presence of rubber mat in front of the D.B (Operator standing Location)						

### Check List for Magnetic Drilling Machine

SL NO	CHECK ITEM	PHOTOS	Y/N	SL NO	CHECK ITEM	PHOTOS	Y/N
1	Fore handle in good operating condition			2	Double insulation provided for the equipment (written in the machine body)		
3	Equipment should be free from any defect like broken Handle, broken parts etc			4	Magnetic base is in charged condition		
5	Presence of Cord strain reliever (glands).			6	Fuse is in good condition		
7	Presence of Drilling trigger switch lock.			8	Electric wire without cuts and joints.		
9	Drilling Bit should be in good condition.			10	Condition and presence of the On/off switch		
11	Presence of dust cleaning brush near the equipment			12	Not to use any gloves while operation & Confirm in built coolant (No Manual)		



### Check List for Excavator

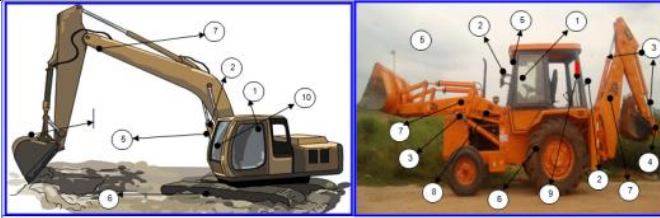

CONTR NAME-		CHECK ITEMS		DATE OF CHECK-			
SL NO	CHECK ITEM	PHOTOS	Y/N	SL NO	CHECK ITEM	PHOTOS	Y/N
1	Front & reverse horn			2	Head & tail lamps(for working at night)		
3	Leakage of oil(in hydraulic & pneumatic systems)			4	Loose bolts (connecting pins)(in bucket,doser and all links)		
5	Back view mirror			6	Roller-crawler / tire condition (check for damaged / missing idle rollers)		
7	Structure beam condition(damage, cut,crack)			8	Diesel, oil and grease spillage.		
9	Fire extinguisher in operator cabin						
10	DOCUMENTS			DOCUMENTS			
10.A	Vehicle valid insurance			10.B	Operator license (heavy duty).		

### Check List for Gas Cutting Set



DATE:		CHECK ITEM		PHOTOS		Y/N	
SL NO	CHECK ITEM	PHOTOS	Y/N	SL NO	CHECK ITEM	PHOTOS	Y/N
1	Protective valve cap firmly fixed for both cylinder(Check for damage/crack in the valve cap)			2	Pressure gauges two for each cylinder(inlet & outlet jare in working condition(both Oxygen & Acetylene gas)		
3	Flash back arrestor (FBAs) is provided at torch side for both acetylene & oxygen			4	Non return valves (NRVs) is provided for both acetylene & oxygen cylinders.		
5	Tight Crimping of hoses with jubilee clamps.			6	Hose free from damage(cut and cracks )		
7	Cylinder secured by chain to the trolley.			8	Trolley tire shall be free from damages.		
9	Availability of industrial type lighter(no match box / commercial lighters).						

### Check List for Ladder

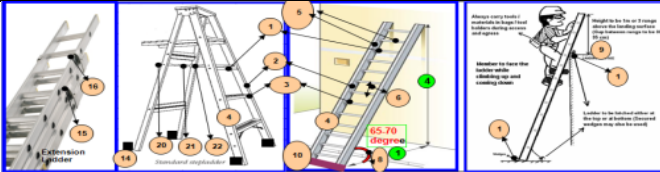

Date:		CHECK ITEM		PHOTOS		Y/N		
SL NO	DESCRIPTION	Day-1	Day-2	Day-3	Day-4	Day-5	Day-6	Day-7
1	All the rungs, cleats, or steps are in good condition (Broken,missing,bend rungs)							
2	Side rails is intact without any cracks, bends, or breaks.							
3	The rungs, cleats, or steps is fit into the side rails without damage.							
4	Ladder is free from corrosion.							
5	Side rails and steps are free of oil or grease.							
6	Rungs are placed at regular intervals (30 cm gap between two rungs)							
7	Projection of loose nails, screws, bolts, or other metal parts							
8	At the time of using, the ladder should be placed at 65-75 degree angle (1:4 ratio)							
9	Ladder is extended at least 1 m above the landing platform (3 Rungs)							
10	Ladder is secured either at top or at the bottom							
11	Ladder rungs should not be painted.							
12	Reinforcement rod should not be used as ladder rungs							
13	The surface of the rungs should not be smooth							
14	Rubber feet for firm grip (in case of Aluminum ladder)							
<b>EXTENSION LADDER</b>								
15	Loose ,missing or broken extension locks							
16	Defective locks which do not seat properly when ladder is extended							
17	loose hinges							
18	Ensure stopper without damage							
<b>STEP LADDER</b>								
19	Step ladder height not to exceed by 20 feet							
20	Loose hinges							
21	Loose or bent hinge spreaders							
22	Ensure spreader without damage and locking mechanism							

### Check List for Portable Grinding Machine

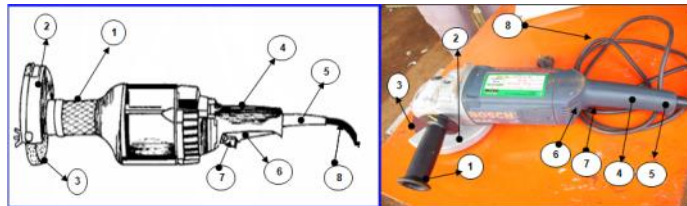

DATE:		CHECK ITEM		PHOTOS		Y/N	
SL NO	CHECK ITEM	PHOTOS	Y/N	SL NO	CHECK ITEM	PHOTOS	Y/N
1	Fore handle without damage.			2	Wheel guard (covering 3/4th area).		
3	Grinding wheel without any crack.			4	Rear handle without any damage.		
5	Presence of Cord strain reliever (glands).			6	Trigger switch without damage.		
7	Presence of Switch lock.			8	Electric wire without cuts and joints.		



### Check Sheet for Fire Extinguisher

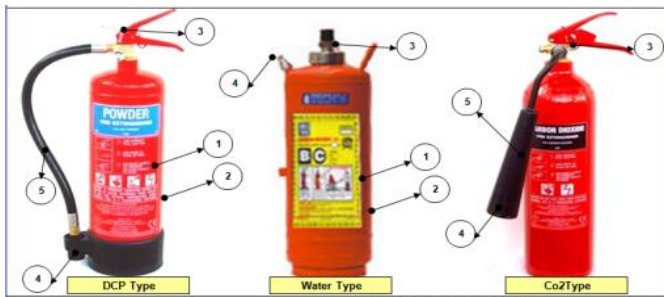

Date: \_\_\_\_\_

CHECK ITEMS (to be checked daily)

SL NO	DESCRIPTION	Day	D1	D2	D3	D4	D5	D6	D7
			MON	TUE	WED	THU	FRI	SAT	SUN
1	Condition of the extinguisher (Clean and Tidy)								
2	Physical appearance for corrosion.								
3	Safety pin in position								
4	Condition of discharge nozzle(any blockage/damage)								
5	Condition of hose(any leakage/broken)								
6	Weight of the extinguisher(Should be match with actual weight written in the body)								
7	Availability of visual board.								
8	All the indicator gages(where fitted)in green segment(not to be red)								
9	Extinguisher is not expired or refilled before refilled date								

### Check List for Scaffold ( Cuplock)

Photo of Resp Person

Name: \_\_\_\_\_

Desig: \_\_\_\_\_

Mob No: \_\_\_\_\_

Location: \_\_\_\_\_

SL NO	CHECK ITEM	PHOTOS	Y/N	SL NO	CHECK ITEMS	PHOTOS	Y/N
1	Display board stating the status of the scaffold ( O K, Not for use or under erection)		M T W Th F Sat Sun	7	Ladder kept in channels over the gables in the first lift and above.		M T W Th F Sat Sun
2	Scaffold erected in a firm base ground.		M T W Th F Sat Sun	8	Each lifts prodded with platform (gales) tied with horizontal pipes.		M T W Th F Sat Sun
3	Sole plate provide in the base of the scaffold as per standard (refer note above) <Full length wooden planks/channels>		M T W Th F Sat Sun	9	All four side supports pipes (Struts) and properly clamped		M T W Th F Sat Sun
4	Baseplate / foot plate of scaffolds verticals are over the wooden planks(sole plate)		M T W Th F Sat Sun	10	Interlocking between the columns & scaffold in case of more than 6 m height scaffolds.		M T W Th F Sat Sun
5	Cuplock locking is not in loose condition		M T W Th F Sat Sun	11	All lifts in the scaffold provided with mid rails (hand rails)		M T W Th F Sat Sun
6	Access ladder from the ground & each lift and secured with clamps.		M T W Th F Sat Sun	12			M T W Th F Sat Sun

### Check Sheet for Tractor



Contractor Name: \_\_\_\_\_ Doc No.: S1UP/HSE/013

Date: \_\_\_\_\_

SL NO	CHECK ITEM	PHOTOS	Y/N	SL NO	CHECK ITEMS	PHOTOS	Y/N
1	Protection (canopies, screens) is provided to shield operator from falling objects.			2	Effective, working horn and reverse alarm		
3	Moving parts, shafts, sprockets, belts, etc are guarded.			4	Protection against contact with hot surfaces, exhaust, etc is provided.		
5	Safe means of access (steps, grab bars, non-slip surfaces) to the cab is provided			6	No Damage in Tire (Crack, cut, air pressure etc)		
7	No Leakage of oil from the vehicle and vehicle oil tank.			8	Vehicle rear view mirror		
9	Head light,Tail lamp are in working condition (for night work)			10	Brake, accelerator, clutch are in good working condition		
11	Lock of the back door (trails) in good condition			12	Inter locking system between the tractor and the trailer.		
13	DOCUMENTS			13	DOCUMENTS		
13.A	Visualization of Check sheet and Operator details with photo in the vehicle staff.			13.B	Vehicle valid insurance		
				13.C	Operator license (LMV atleast) & LD Card		

### Check List for Arc Welding Machine

SL NO	CHECK ITEM	PHOTOS	Y/N	SL NO	CHECK ITEM	PHOTOS	Y/N
1	ON / OFF knob is provided(Check for damage and uninsulated knob)			2	Regulator with indicator is provided		
3	Welding cables connected to the welding machine with lugs at the joints			4	No damage in the insulation of welding cables		
5	Electrode rod holder and earthing holder are without damage			6	Industrial type Plug for power tapping cable of welding machine		
7	No internal live electrical parts of welding machine is exposed			8	Trolley without damaged wheels		
9	Fire extinguisher and fire bucket with sand availability						

### Check Sheet for Truck ( Lorry / Tipper)



SL NO	CHECK ITEM	PHOTOS	Y/N	SL NO	CHECK ITEMS	PHOTOS	Y/N
1	Number plate in front and back side		M TU W TH FR SA SU	2	No Damage in Tire ( Crack, cut, air pressure etc).		M TU W TH FR SA SU
3	No air leak in the air tank.		M TU W TH FR SA SU	4	Front and reverse horn.		M TU W TH FR SA SU
5	No oil leak from the diesel tank.		M TU W TH FR SA SU	6	Fire extinguisher in driver cabin.		M TU W TH FR SA SU
7	Head and tail lamps (for night working).		M TU W TH FR SA SU	8	Breck, Clutch and accelerator are in working condition		M TU W TH FR SA SU
10	Rear view mirror		M TU W TH FR SA SU	9	Truck is Not overloaded		M TU W TH FR SA SU
11	Wind shield with wiper		M TU W TH FR SA SU	11	Wind shield with wiper		M TU W TH FR SA SU
11	DOCUMENTS			11	DOCUMENTS		
12.A	Vehicle valid insurance			12.B	Operator license (heavy duty).		
12.C	Emmision Test			12.D	Road tax		

### Check List for Motor Mixer ( Concrete Mixer)



Date: \_\_\_\_\_ Contractor: \_\_\_\_\_ Doc. No. : STUP/HSE/016

Sl. No.	DESCRIPTION	Day	Day-1 Mon	Day-2 Tue	Day-3 Wed	Day-4 Thu	Day-5 Fri	Day-6 Sat	Day-7 Sun
1	Condition of base								
2	Presence of the mixer round handle stopper								
3	Condition of the m/c stand with wheel								
4	Presence of the guard for the chain and pulley								
5	Condition of the sling of the feeder								
6	Cover of the starter								
7	Condition of radiator								
8	Condition of belt								
9	Condition of chain								

### Check List for Hydraulic Punching Machine



Date: \_\_\_\_\_ Contr. Name: \_\_\_\_\_ Doc No.: STUP/HSE/017

SL NO	CHECK ITEM	PHOTOS	Y/N	SL NO	CHECK ITEM	PHOTOS	Y/N
1	Working condition of the foot operating pedal			2	Working condition of the job clamp & working platform		
3	Safety guard for rotating part of the machine			4	Working condition of emergency push button		
5	Condition of switch board & switches			6	Safety guard for flying object		
7	Available of steel strip collection box			8	Working condition of the adjustable light		
9	Provision of Industrial type socket & body earthing						

**LEGEND**  
 YES(Y) ○  
 NO(N) X

### Check List ( Pre Entry) for Hydraulic Rotary Rig

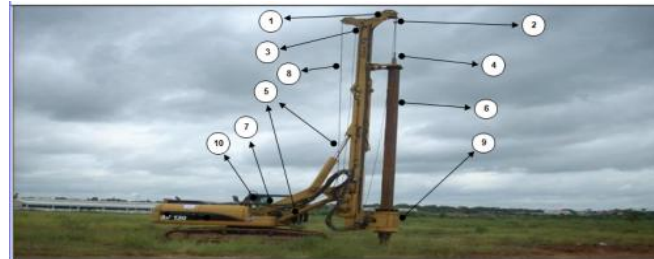

CHECK ITEMS

Sl.No	Check items	Mon	Tue	Wed	Thu	Fri	Sat	Sun
1	Check the Derrick Pulleys for damages and pin locking.							
2	Working condition of the auxiliary winch Hoist limit switch.							
3	Working condition of the Kelly Bar Limit Switch on the Mast.							
4	Check the wire sling connections on the Kelly Bar for loose or damaged U bolts and broken wires.							
5	No oil leak in hydraulic parts.							
6	Kelly Movement and working condition (damage, crack and jamming while extending).							
7	Working condition of the Emergency Lever in the Operator Cabin.							
8	Wire ropes shall be free from Damages (No Kinks and broken wires).							
9	Rotary Head support Connecting Pins to the mast (Crack, Damage).							
10	Fire extinguisher provision in the operator cabin.							
11	Availability of the Head and tail lamps (for night working).							
12	Provision of rear view mirrors, front and reverse horn.							
13	Operator should have a valid license.							



### Check List ( Pre Entry) for Conventional Bore Pile Rig



Date:		CHECK ITEMS						
Sl No	Description	Mon	Tue	Wed	Thu	Fri	Sat	Sun
1	Guards for rotating parts (Gear,Pulley,Coupling etc)							
2	Position of winch on wooden support(Excentric placement of winch in wooden member)							
3	Side anchoring of winch machine to withstand on vibration							
4	Working condition of Break mechanism/lever							
5	Wire rope fixed properly with winch drum using D clamps							
6	Defectin wire rope(kinks,twist,cor-out,stands(pinch beyond 10%in N.G)							
7	Tripod pulley condition(centre pin,inner side of the pulley surface should be free from damage,rough and							
8	Joint of the wire rope with the bore hammer fixed by 3 clamps on equal distances							
9	Tripod beams conditions(no crack, damage joints with bolt &nuts)							
10	Tripod leg shoe anchoring done							
11	Ladder in one tripod leg(rungs strength, bent and regular interval)							
12	For anchoring of safety belt, U shape hooking arrangements at the top of the tripod ladder side							
13	Diesel tank stand positioning and leakage of oil from the tank							
14	Fire extinguisher of 5 kg and fire bucket with sand availability at the rig point.							

### Check List Portable Welding DG Set



Date:		CHECK ITEMS							
SL. No	DESCRIPTION	DAY	D- 1 MON	D- 2 TUE	D- 3 WED	D- 4 THU	D- 5 FRI	D- 6 SAT	D- 7 SUN
1	ON / OFF knob is provided (Check for damage and uninsulated knob)								
2	Welding cables connected to the welding machine with lugs at the joints								
3	No damage in the insulation of welding cables								
4	Electrode rod holder and earthing holder are without damage								
5	No internal live electrical parts of welding machine is exposed								
6	Trolley without damaged wheels and wheel stopper provided								
7	Fire extinguisher and fire bucket with dry sand availability								
8	Earthing to be provided for Machine								
9	M/c Should be placed on rigid / even place and protect from Nature calamity (Rain....)								
10	Rotating Parts covered with safe guard								
11	Diesel leakage from the diesel tank & Ensure the diesel tank cap								

### Check List for Ripper & Dozer



Date:		PHOTOS		PHOTOS	
SL.RO	CHECK ITEM	Y/N	SL.RO	CHECK ITEM	Y/N
1	Front & reverse horn		2	Head & tail lamps(for working at night)	
3	Leakage of oil(in hydraulic & pneumatic systems)		4	Loose bolts /connecting pins(in ripper, dozer and all links)	
5	Back view mirror		6	Ripper teeth condition(damage, cut, crack)	
7	Dozing blade condition(damage, cut, crack)		8	Diesel, oil and grease spillage.	
9	No Damage in Tire (Crack, cut, air pressure etc).		10	Fire extinguisher in operator cabin.	
11	Seat, Seat belt &mounting, damage, wear, crack		12	Availability of Signal man with Green and Red Flag	
13	Operator and signal man using required PPE's like Ear plug, Dust mask, etc.		14	Operator and vehicle details displayed on the cabin	

### Check List for Road Roller ( Vibrator & Soil Compactor)



Date:		CHECK ITEMS							
SL. NO	DESCRIPTION	Day	Day-1 Mon	Day-2 Tue	Day-3 Wed	Day-4 Thu	Day-5 Fri	Day-6 Sat	Day-7 Sun
1	Tires,wheels,Lug Nuts, steam cap-If any inflation leaks, damage,wear								
2	Leveling Blade-Excessive wear, Damage,Leaks								
3	Drum Scrapers-Excessive wear, Damage								
4	Drum Cooling oil & Vibratory support-Leaks								
5	Electric Weight Housing & Hydraulic Filters -Leaks								
6	Isolation Mounts-Damage,cracks,spitting								
7	Steering cylinders/Ends-Damage, Wear,Leaks								
8	Steps and handholds-Condition, cleanliness								
9	Underneath m/c-Leaks, Damage								
10	Hydraulic tank and Fuel Tank-Fluid level, Damage,Leaks								
11	All covers and Guard-Damage, security Attached								
12	Light, Front and Rear,Beacon-Function, Damage to lens, Housing or Engine oil and engine coolant-Fluid level								
13	All hoses-Crack, wear spots, leaks								
14	All belts-Tension, Wear, Cracks								
15	Overall engine compartment-Trash, loose nuts & Bolts								
16	Seat, Seat belt &mounting-Adjustment, damage,wear,crack								
17	Horn,Backup Alarm,light,indicator light Proper functioning								
18	Presence of fire extinguisher and its condition inside the cab.								
19	Gauges,indicators, Switches,controls-Damage, functioning								
20	Presence of rear mirror and its condition								
21	Presence of vehicle R, T O document and driving license of the driver								
22									



### Check List for Diesel Generator



DATE: \_\_\_\_\_

SL NO	DESCRIPTION	Day	Day-1 Mon	Day-2 Tue	Day-3 Wed	Day-4 Thu	Day-5 Fri	Day-6 Sat	Day-7 Sun
1	Guard provided for all exposed rotating parts.								
2	Hot surface is provided with guard & signage.								
3	Rubber mat is provided in operator standing area (around the D.G)								
4	No oil leakage from the oil tank & other parts of the m/c.								
5	Wheel stopper in case of vehicle mounted D.G								
6	Proper access to the D.G control panel								
7	Exhaust smoke pipe faced upwards & outside of D.G shelter.								
8	Dip tray for any oil leakage.								
9	Drive belt is in good condition (any cut, dent or damage)								
10	Adequate ventilation in case of indoor generator								
11	Presence of fire extinguisher (ABC type)								
12	Presence of damage free operating switch, Voltage and temperature meter, circuit breaker, Oil level indicator, Emergency switch.								
13	Earthing is provided with standard earthing pit.								
14	In case of mobile gen set, confirmation of inbuilt acoustic system (if sound is more than 85 db)								
15	Authorized Members PHOTO / Shift Timings & CONTACT No. Details Available								

### Check List for Cherry Picker

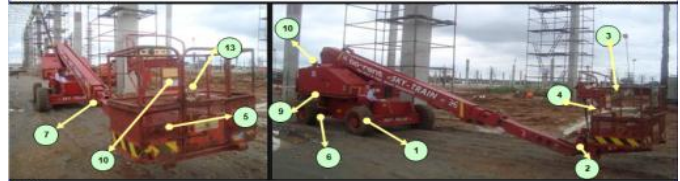

DATE: \_\_\_\_\_

SL NO	DESCRIPTION	Day	Day-1 Mon	Day-2 Tue	Day-3 Wed	Day-4 Thu	Day-5 Fri	Day-6 Sat	Day-7 Sun
1	No Damage in Tire (Crack, cut, air pressure etc).								
2	Platform is securely fastened to platform support.								
3	Ensure not more than 3 members loaded at a time in the platform / Bucket.								
4	All member in the platform should have safety belt								
5	Foot pedal in the bucket is in working condition.								
6	Outriggers & extendable axes are in smooth working condition. (If Any)								
7	High engine and height drive cutout is in working condition.								
8	Any oil leakage in the Hydraulic systems.								
9	LOTO system is available in the ground panel board.								
10	Warning lamp is in working condition.								
11	The cherry picker movement/ work area is leveled, compacted and free from all obstructions								
12	Operator details (Photograph, Licence, Mobile no, Cherry picker details etc) displayed in the cabin.								
13	Member should not stand while bucket going up or coming down time								

### Check List for Plate Compactor & Walk Behind Roller



DATE: \_\_\_\_\_

SL NO	DESCRIPTION	Day	Day-1 Mon	Day-2 Tue	Day-3 Wed	Day-4 Thu	Day-5 Fri	Day-6 Sat	Day-7 Sun
1	Presence of name plate, operation and safety details / Instruction								
2	Presence & condition of all parts like hook vibration insulator etc and no loosen screws								
3	Condition of the fuel tank and tank lid with cap								
4	All moving / Exposed parts covered with safety guard								
5	Malfunctioning, broken or missing parts								
6	Safety oriented devices, such as removable safety devices, emergency shut-off equipment, sound-proofing elements & exhausts, are in place & fully functional.								
7	PPE'S: Hand gloves, Ear plug, Nose mask & Goggles								
7	Ensure the operating person is well trained								

### Check List for Hammering / Drilling Machine



DATE: \_\_\_\_\_

SL NO	DESCRIPTION	Day	Day-1 Mon	Day-2 Tue	Day-3 Wed	Day-4 Thu	Day-5 Fri	Day-6 Sat	Day-7 Sun
1	Equipment should be double insulated (written on the machine body)								
2	Equipment should be free from any defect like broken Handel, broken parts etc								
3	Wire should be free from wrinkle and any defect.								
4	Wire plug top should be present.								
5	Drilling Bit should be in good condition.								
6	Presence of drilling bit holder								
7	Condition and presence of the switch								
8	Presence of rear handle & cable gland								
9	PPE'S: Face shield Must to carry out while handling of portable Drilling Mic.								
10	Not to use any gloves while drilling operation								

### Check List for Chops Saw Machine

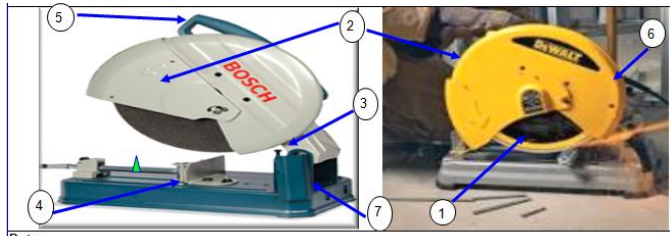

Date: \_\_\_\_\_

SL NO	DESCRIPTION	Day-1	Day-2	Day-3	Day-4	Day-5	Day-6	Day-7
		Mon	Tue	Wed	Thu	Fri	Sat	Sun
1	Crack & Damage of the Cutting plate							
2	Presence of Cutting plate guard & Secondary adjustable guard							
3	Presence of locking system for the plate & Guard							
4	Presence of job clamp and its condition							
5	Presence of handel and its condition							
6	Cable condition(Any cut,wear etc) and presence of wire top plug							
7	Presence cutting dust guard/spatter guard							
8	PPE's: Face sheild, hand gloves, ear plug.							

### Check Sheet for Tough Rider



DATE: \_\_\_\_\_

SL NO	DESCRIPTION	Day	Day-1	Day-2	Day-3	Day-4	Day-5	Day-6	Day-7
		Mon	Tue	Wed	Thu	Fri	Sat	Sun	
1	Physical damage in body of the vehicle and in the bucket								
2	Working condition of the vehicle forward and reversed gear								
3	Working condition of the hydraulic brakes (4 wheels)								
4	Oil leakage from the hydraulic cylinder and from the diesel tank.								
5	Starter shaft covered by guard								
6	No Damage in Tire(Crack, cut, air pressure etc).								
7	Driver seat hood is available and no damage								
8	Head and tail lamps (for night working).								
9	Exhaust pipe is bended outside(Not faced on operator)								
10	Working condition of Front & Reverse horn								
10	Operator license.								

### Check List for Thread Make Machine



Date: \_\_\_\_\_

SL NO	DESCRIPTION	Day-1	Day-2	Day-3	Day-4	Day-5	Day-6	Day-7
		Mon	Tue	Wed	Thu	Fri	Sat	Sun
1	Crack & Damage of the Cutting plate							
2	Working condition of foot pedal/ handle.							
3	Presence of safe guard for rotating parts of the machine & internal live electrical parts.							
4	Presence of job clamp and its condition							
5	Presence of coolant water fixed with machine.							
6	Cable condition(Any cut, wear etc) and presence of wire top plug							
7	Presence of wire brush & Bottom cover.							
8	PPE's: Goggle, hand gloves, Helmet & Safety Shoe.							

### Check List for Grove Cutting Machine



Date: \_\_\_\_\_

SL NO	DESCRIPTION	Day-1	Day-2	Day-3	Day-4	Day-5	Day-6	Day-7
		Mon	Tue	Wed	Thu	Fri	Sat	Sun
1	Crack & Damage of the Cutting plate							
2	Presence of Cutting plate guard							
3	Presence of guard for rotating parts of the machine/belt							
4	Presence lid /cap for petrol & water tank							
5	Presence of balde adjustable handel and its condition							
6	Cable condition(Any cut,wear etc) and presence of cable top plug							
7	No Damage in Tire (Crack & cut, etc)							
8	Condition of the starter rope with handle							
9	PPE's: Goggle, hand gloves, ear plug.							



### Check List for Bar Cutting Machine

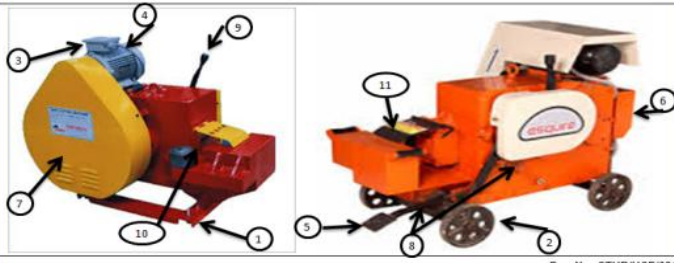

Doc No.:STUP/HSE/031

SL NO	DESCRIPTION	Day	Day-1	Day-2	Day-3	Day-4	Day-5	Day-6	Day-7
			Mon	Tue	Wed	Thu	Fri	Sat	Sun
1	Erected in a firm base concrete platform.								
2	Machine is grouted properly/ Base wheel stopper provided								
3	Body Earthing is provided								
4	D B box connected with the machine is equipped with MCB and ELCB.								
5	Working condition of Foot pedal								
6	Power on & off switch with indicator light are available in working condition.								
7	Belt and other internal moving parts are covered/Guarded.								
8	No oil leakage								
9	Working condition of cutting handle.								
10	Cutting blade is free from damage.								
11	Availability of safe guard for cutting area								

### Check List for Power Travelling Machine



Doc No.:STUP/HSE/032

SL NO	DESCRIPTION	Day	Day-1	Day-2	Day-3	Day-4	Day-5	Day-6	Day-7
			Mon	Tue	Wed	Thu	Fri	Sat	Sun
1	Working condition of control switch								
2	D B box connected with the machine is equipped with MCB and ELCB.								
3	Belt and other internal moving parts are covered/Guarded.								
4	Openings to be covered with separate Chicken mesh/any other mesh.								
5	No damage in rotating blade								
6	Hand control device in working condition.								
7	Cable gland for inlet & outlet power connection.								
8	No damages in handle, machine body								
9	No damages in cable & industrial type socket.								
10	PPE's: Gumboot, Goggle, Ear plug, Reflective Jacket, Rubber gloves & Helmet.								

### Check List for Dewatering Machine



Doc No.:STUP/HSE/033

SL NO	DESCRIPTION	Day	Day-1	Day-2	Day-3	Day-4	Day-5	Day-6	Day-7
			Mon	Tue	Wed	Thu	Fri	Sat	Sun
1	Working condition of starter switch								
2	D.B box connected with the machine is equipped with MCB and ELCB.								
3	Belt and other internal moving parts are covered/Guarded.								
4	Working condition of the pressure gauge.								
5	Separate body earthing provided for machine.								
6	No Damage in Tire (Crack & cut, etc)								
7	Cable gland for inlet & outlet power connection.								
8	No damages in handle, machine body								
9	No damages in cable & industrial type socket.								
10	Outlet water pipe connected with Jubilee clamp								

### Check List for Wood/Granite Cutting Machine

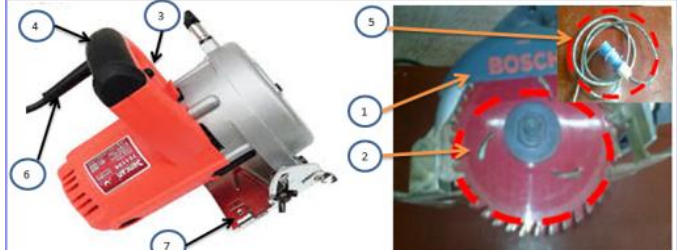

Doc No.:STUP/HSE/034

SL NO	DESCRIPTION	Day	Day-1	Day-2	Day-3	Day-4	Day-5	Day-6	Day-7
			Mon	Tue	Wed	Thu	Fri	Sat	Sun
1	Wheel guard (Covering 3/4th area)								
2	Cutting wheel without any damages/cracks.								
3	Condition of the ON/OFF switch.								
4	Presence of handle gripper & its condition. (Wear, Damages)								
5	Industrial type Plug for power tapping cable of cutting machine & Condition of the cable.								
6	Presence of cord strain reliever (Glands)								
7	Condition of the base plate (Damages, Cracks)								
8	Cooling water connected with machine while granite cutting								
9	PPE's: Face shield, Hand gloves, Nose mask, Ear plug, Helmet, Shoe, Reflective jacket.								
10	Working condition of adjustment alignment key of base plate.								

## Check List for Mobile Scaffold

STANDARDS OF MOBILE SCAFFOLD

Photo of Resp Person

Name- \_\_\_\_\_

Desig- \_\_\_\_\_

Mob No- \_\_\_\_\_

Location- \_\_\_\_\_

Contractor Name:			Date:				
SL NO	CHECK ITEM	PHOTOS	Y/N	SL NO	CHECK ITEMS	PHOTOS	Y/N
1	Display board stating the status of the scaffold ( O.K, Not for use or under erection)		M	6	Guard rail has been provided as per standard Mid rail @ 0.55m and Guard rail @ 1.1m		M
			T				
			W				
			Th				
			F				
2	Scaffold erected in a firm base ground.		M	7	Proper access way to the top of the scaffold (Good Ladder condition)		M
			T				
			W				
			Th				
			F				
3	Availability of wheel lock in all the four wheels		M	8	The scaffold width and height ratio should be 1:3		M
			T				
			W				
			Th				
			F				
4	Four out riggers are available in four sides of the scaffold		M	9	Cross barcing has been provided in the scaffold		M
			T				
			W				
			Th				
			F				
5	Thickness of Working platform is minimum of 0.15m /secured condition of platform.		M	10	Height work banner displayed		M
			T				
			W				
			Th				
			F				

Some of the other formats are also given below:

**1.0 GENERAL HSE INSPECTION CHECKLIST**

Name of Project :

Job No. :

Area Inspected :

Inspected By :

Date :

Sl. No.	Activities	Observation	Measures
	<b>PILING WORK</b>		
1	Condition of tripod and its stability		
2	Condition of wire ropes, D shackles, Bulldog Grips etc.		
3	Removal of loose earth, slush etc.		
4	Entry in register, details of periodical checking & maintenance		
5	Guards for rotating parts of machines		
	<b>EXCAVATION</b>		
1	Verification of underground electrical cable		
2	Condition of storing material		
3	Cutting earth from top & ensuring no undercutting		
4	Storing of material from the edge of excavated pit 5' or half of the depth whichever is more		
5	Barricade / Fencing/ Displaying of danger sign, warning sign by way of red flag / tape / light etc.		
6	Provision of dewatering facilities		
7	Provision for ladders for deep trench		
8	Stability of nearby structure		
9	Avoid traffic movement, piling work in the vicinity		

Sl. No.	Activities	Observation	Measures
<b>DEMOLITION</b>			
1	Cordoning of surrounding area		
2	Displaying of warning sign Red Flag/Tape/ Light etc.		
3	Demolition from top in a planned manner		
4	Disconnection of electrical cable connection/ water/ steam /gas line etc.		
5	Removal of debris immediately to a safe place		
6	Emergency Transport		
7	Fire extinguishers kept nearby for emergency		
<b>BLASTING</b>			
1	Blasting record incorporating number of holes made / type of explosive used / firing pattern and sequence with date & time of blast		
2	Handling of explosives by licensed blaster		
3	Intensity of the charge calculated before use		
4	Before drilling presence of unfired explosives checked		
5	Blasting is carried out only during lean hours say lunch / night hours		
6	Standard warning signal / all clear signal before and after firing is ensured		
7	Competent persons equipped with red flags are posted at possible approaches to stop traffic and by-passers		
<b>GROUND SURFACES</b>			
1	Ground level , no soft spot		
2	Footing timber level adequately supported		
3	No Unauthorised entry		

Sl. No.	Activities	Observation	Measures
<b>SCAFFOLDS</b>			
1	Base plate level		
2	Spindle jack vertical		
3	Standard plumb (vertical tubes), no damage		
4	Ledgers level (horizontal tubes), no damage		
5	Diagonal bracing, secure and not missing		
6	Lock pin in place and secure		
7	Support from permanent structure		
<b>LADDERS</b>			
1	Placed on level ground		
2	Position at an angle of 1:4		
3	Adequately secured		
4	No damage, check welds		
5	Extend 4 rungs above stepping off point		
6	Uniform and proper spacing of rung		
<b>WORKING PLATFORM</b>			
1	Should not be less than 600 mm wide		
2	Guard rails adequate check		
3	Boards free of defects check		
	i) Top rail at least 910 mm height		
	ii) No gap greater than 470 mm		
	i) No gaps		
	ii) Adequate supports		
	iii) No risk of trips		
	iv) Properly secured / tied		
<b>PPE</b>			



Sl. No.	Activities	Observation	Measures
1	Helmet and footwear worn		
2	Safety harnesses as required and secured above shoulder level		
3	Use of safety harnesses while working at height		
4	Safety Goggles during welding / gas cutting / grinding etc.		
5	Condition / Maintenance of safety appliances		
6	Use of body guards, gloves etc.		
	<b>STRUCTURAL FABRICATION &amp; ERECTION</b>		
1	All electrically operated equipments have proper earthing and connected through RCCB.		
2	Safety guards for drilling & grinding machine are in position		
3	Use of Scotch block / wedge on wheels of trailers during unloading of material		
4	End stoppers fixed and maintained for rail mounted gantry cranes and limit switches are in operating condition		
5	Checking lifting tools & tackles before use		
6	Precaution during slinging on sharp edges		
7	Signalling to crane operators by one person at a time		
8	Withdrawal of persons beneath suspended load		
9	Cordoning on all sides displaying Red Flags / Tape / Light and warning signs		
10	Load to be lifted is properly ascertained to identify centre of gravity etc.		
11	Clear passages of men, posts, material etc. and easy access for cranes to move with suspended loads		

Sl. No.	Activities	Observation	Measures
12	Proper tag line is used for guiding lifting loads		
13	Proper sequence of erection is followed		
14	Guy ropes are used and secured during and after erection of heavy lift		
15	Wire ropes are maintained and its safe working load inscribed		
16	Adequate illumination provided		
<b>GAS CUTTING AND WELDING</b>			
1	Storing of gas cylinder like DA, Oxygen full & empty etc.		
2	Proper handling of gas cylinder		
3	Condition of regulator, hose, torch etc.		
4	Welding generators / transformers condition and its proper earthing		
5	Condition of welding cable and joints		
6	Electrode holder		
7	Area free from combustible material		
8	Cordoning when Welding / Gas cutting is in progress at height		
9	Provision of fire extinguishers		
10	Smouldering fires are religiously extinguished after day's job		
11	Stacking of cylinders not near live wires, battery charging rooms / oil rooms		
<b>MEANS OF ACCESS</b>			
1	Platform, toe board and railings		
2	Scaffolding - its condition and Maintenance		
3	Staircase and railing		

Sl. No.	Activities	Observation	Measures
4	Ladder & fixing		
5	Safe access to and from means of access		
<b>ELECTRICAL WORKS</b>			
1	Earthing of electrically operated equipment		
2	Provision of Shed / Canopy / cover for distribution board and sub-distribution board		
3	Insulation of cables and joints		
4	Cable laying above 7' from ground level		
5	Fire extinguishers at main distribution board room		
6	Periodical checking of portable tools		
7	Use of RCCBs		
8	"Men Working Don't Switch On" board and other related warning boards and tags		
9	Insertion of loose wire in sockets		
10	Use of proper plug and sockets		
11	Risk Assessment for shutdown jobs and its implementation		
12	Permit to work		
<b>HOUSEKEEPING</b>			
1	Material stacking and storing		
2	Working / moving area clean		
3	Access / Main Approach / Passages free from obstacles		
4	Cordoning / covering of pit, vat, machine foundation etc.		
5	Displaying of Red Flags / Tape / light.		

Sl. No.	Activities	Observation	Measures
6	Removal of unwanted materials like excavated earth debris etc.		
<b>FIRE PREVENTION / PROTECTION</b>			
1	Combustible material away from source of heat / fire		
2	Provision of fire extinguishers and its maintenance		
3	No Smoking Board / Caution Board displayed		
4	Stacking / Storing of different type of combustible materials		
<b>ROAD SAFETY</b>			
1	Driving by unauthorised person		
2	Loading of material on truck, dumper, securely		
3	Material falling from vehicle while transporting		
4	Speed limit		
5	Transportation of persons by dumper		
6	Going up and coming down from moving vehicle		
7	Indulging in horse play on job		
8	Reverse horn		
9	Location of Overhead lines identified and precautions taken		
<b>MISCELLANEOUS</b>			
1	First Aid box with proper medicine and its maintenance		
2	Validity date of medicine		
3	Illumination		
4	HSE boards and promotional materials		
i)	Posters		

<b>Sl. No.</b>	<b>Activities</b>	<b>Observation</b>	<b>Measures</b>
5	ii) Stickers Arrangement of drinking water and sanitation		
6	Provision of emergency vehicle		

## 2.0 WORKING AT HEIGHT INSPECTION CHECKLIST

Name of Project :  
 Job No. :  
 Inspected By :  
 Date :

Sl. No.	Points	Observation	Measures
1	All the workers have been explained safe work-procedures?		
2	An established communication system available and explained to the workers?		
3	Adequate illumination has been ensured?		
4	Workplace inspected prior to start of work?		
5	Area below the workplace barricaded, especially below hot-works?		
6	Workmen provided with bag / box to carry bolts, nuts and hand tools?		
7	Arrangement for fastening hand tools made?		
8	All work platforms are of adequate strength & ergonomically suitable?		
9	Fabricated make shift arrangements are checked for quality and type of material welding, anchoring etc?		
10	<i>Work at more than one elevation at the same segment is restricted?</i>		
	<b>ACCESS / EGRESS</b>		
1	Walkways provided with hand-rail, mid-rail & toe guard?		
2.	All chequered plates, gratings properly welded / bolted?		

Sl. No.	Points	Observation	Measures
3	Are ladders inspected and whether they are maintained in good condition?		
4	Are ladders spliced?		
5	Are ladders properly secured to prevent slipping, sliding or falling?		
6	Do side-rails extend 36" above top of landing?		
7	Are built up ladders constructed of sound materials?		
8	Rungs and cleats not over 12" on centre?		
9	Metal ladders not used around electrical hazards?		
10	Proper maintenance and storage ensured?		
11	Ladders placed at right slope?		
12	Ladders, staircases welded/bolted properly?		
13	Any obstruction in the stairs?		
14	Are landings provided with handrails, knee-rails, toe-boards etc.?		
15	Whether ramp is provided with proper slope?		
16	Proper handrails provided in ramps?		
	<b>HOUSEKEEPING</b>		
1	<i>Walkways, aisles &amp; all overhead workplaces cleared of loose material?</i>		
2	<i>Flammable materials, if any, are cleared?</i>		
3	<i>All shuttering materials are removed after de-shuttering is done?</i>		
4	<i>Platforms and walkways free of oil / grease or other slippery spillage?</i>		
5	<i>Collected scrap are brought down or lowered down &amp; not dropped from height?</i>		



Sl. No.	Points	Observation	Measures
	<b>PPE &amp; SAFETY DEVICES</b>		
1	Use of safety helmets, full body harnesses ensured for all workers?		
2	Anchoring point provided at all places of work?		
3	Common lifeline provided wherever linear movement at height is required?		
4	Safety nets are in use wherever required?		
5	Proper fall arrest system is deployed at critical work places?		
6	Crawler boards / Safety system for work on fragile roof are used?		

### 3.0 HOUSEKEEPING INSPECTION CHECKLIST

Name of Project :

Job No. :

Inspected By :

Date :

Sl. No.	Points	Observation	Measures
	<b>STRUCTURAL FABRICATION / ERECTION SITE</b>		
1	Walkways, passages kept clear of materials?		
2	Area & roads kept clear for manoeuvring of cranes and material handling equipment?		
3	Scrap, cut-pieces, welding electrode stubs, hand-tools kept tidy in workplace and disposed suitably?		
4	Scrap-bin available in adequate number?		
5	Welding cables, power cables routed properly to avoid run-over by vehicle or tripping hazards?		
6	Compressed gas hoses routed properly?		
7	At least 1 metre on both sides of gantry rails is kept clear of material?		
8	Floor kept clear of water, oil spillage / accumulation?		
	<b>CIVIL WORK AREA</b>		
1	All approach, aisle, ingress / egress to and from work area, excavated pits, ramps, walkways kept clear of debris, tools etc?		
2	Scaffolding materials (H-beam, HD tower frames, bracing, clamps) shuttering boards etc. are stacked properly at site?		
3	Stacking of bricks, hollow blocks are done in safe manner?		
4	Nails removed from wooden planks / timber and not protruding out?		

Sl. No.	Points	Observation	Measures
5	Saw dust, wood chips & scrap wood cleared from carpentry shop and disposed suitably?		
6	Debris from demolition and excavated earth cleared from workplace and access?		

Sl. No.	Points	Observation	Measures
	<b>ELECTRICAL INSTALLATIONS &amp; BOOTHS</b>		
1	Approach to DB, Panels, Switches kept clear?		
2	Fire extinguishers installed at locations where they are easily accessible?		
3	Welding cables and power cables are routed separately?		
4	Routing of cables are done properly to avoid obstruction & tripping hazards?		
5	Floor of electrical booths kept dry?		
6	Rubber mats are in place at electrical panels?		
	<b>STORES</b>		
1	Walkways, entry and exits kept clear?		
2	Materials placed on racks safely accessible?		
3	Compressed gas cylinders are segregated as full or empty and type of gas?		
4	Vertically stored cylinders are secured / chained to avoid toppling and horizontal ones guarded against rolling down?		
5	Flammable storage areas are isolated from store, office and work areas?		
6	Cement bags are stacked in proper gradient safely?		
7	Corrosive material (e.g. acids, alkalis) stored away from other material & kept on collection trays to		

Sl. No.	Points	Observation	Measures
	safeguard against accidental leakage?		
8	Storing area for lifting tools & tackles, ropes, wire ropes & PPE is dry, clean & free of corrosive material?		
9	Easy accessibility to installed fire extinguishers ensured in store?		
	<b>GENERAL</b>		
1	Separate scrap yard allocated for the project?		
2	Approach to workstations, offices, time offices, stores, P&M are well laid and demarcated?		
3	Roads are kept clear of stacked material for free & safe vehicular movement?		
4	Heavy materials stacking are taken care of to prevent slips, collapse and rolling?		
5	For housekeeping at elevated workplaces refer to IM-09-A2.		

#### 4.0 CHECKLIST FOR SCAFFOLDING INSPECTION

Name of Project :

Job No. :

Inspected By :

Date :

Sl. No.	Points	Observation	Measures
1.	Is there a practice of providing suitable and sufficient scaffolds so that the work could safely be done at a height?		
2.	Are properly trained / experienced workmen engaged for scaffolding works?		
3.	Are scaffold platforms designed / constructed with a safety factor of minimum four?		
4.	Is Scaffold Tag System is in use?		
5.	Is there a safe means of access to the working platform?		
6.	Are scaffold structures having a solid base avoiding pavements, manhole covers etc?		
7.	Proper distance from excavation pit is maintained?		
8.	Is verticality of the structure maintained?		
9.	Are ties for scaffold structure properly maintained (vertical & horizontal position)?		
10.	Is there a provision of toe-boards / guardrails and are they secured?		
11.	If wooden plank, whether thickness is maintained as per standard? viz. a. For 1.5 M span - 1.5" thick b. For 2.6 M span - 2.0" thick		
12.	Is there a system of inspecting the scaffolds by a competent person atleast once a week and also after every prolonged interruption in the work?		
13.	Is there a system of inspecting materials of scaffolds on each occasion before erection?		
14.	Is there a system of inspecting scaffolds at every spell of bad weather / heavy wind condition?		
15.	Is overhanging of the working platform as per norms?		
16.	Is there a check for the condition and correct		

Sl. No.	Points	Observation	Measures
	usage of fittings for scaffolds?		
17.	Is the width of a working platform properly maintained according to usage? viz. a. Minimum 600mm for footing only and not for deposit of materials b. Minimum 800mm for footing and deposit of materials c. Minimum 1050mm when used for heavier loads or to support higher platforms		
18.	Are all the materials stored on the platforms properly secured or not?		
19.	Whether planks are tied properly?		
20.	Are openings in working platform kept safely covered / fenced?		
21.	Do wheels used for scaffold tower of appropriate SWL with locking arrangements?		
22.	Are mobile scaffolds used on a firm and level surface?		
23.	Does the height of mobile scaffolds exceed four times the smaller base dimension?		
24.	Are all materials stacked on the platform properly secured while in motion?		
25.	Is the safety rule not to ride on a scaffold while in motion violated?		
26.	Are suitable / correct lifting tackles (wire-ropes / chains / shackles) selected for suspension & used?		
27.	Are all the suspension gears correctly spaced and connected?		
28.	Is there a system of using manila rope / coir rope for suspension at any place where such rope would be liable to damage by heat/flames/sharp edges etc?		
29.	Is hanging platform secured?		

## 5.0 ELECTRICAL SAFETY INSPECTION CHECKLIST

Name of Project :  
Job No. :  
Inspected By :  
Date :

Sl. No.	Points	Observation	Measures
	<b>CABLES</b>		
1	Whether the condition of Cable is checked?		
2	Are Cables received from other site checked for Insulation Resistance before putting them into use?		
3	Are all main Cables, taken either underground / Overhead?		
4	Are welding Cables routed properly above the Ground?		
5	Are welding & electrical Cables overlapping?		
6	Is any improper jointing of Cables wires prevailing at Site?		
	<b>DBs / SDBs</b>		
1	Is earth conductor continued upto DB / SDB?		
2	Whether DBs & extension boards are protected from rain / water?		
3	Is there any overloading of DBs / SDBs?		
4	Are correct / proper fuses & CB's provided at main boards & sub- boards?		
5	Is energised wiring in junction boxes, CB panels & similar places covered all times?		
6	Is periodical maintenance done and loose connections are avoided?		

Sl. No.	Points	Observation	Measures
	<b>RCBO / RCCB</b>		
1	Whether the connections are routed through RCBO / RCCB?		
2	Is RCBO/RCCB sensitivity maintained at 30 mA?		
3	Are the RCBO/RCCB numbered & tested periodically & test results recorded in a logbook countersigned by competent person?		
	<b>EARTHING</b>		
1	Is neutral earthing ensured at the source of power (Main DB at Gen. or Transformer)?		
2	Whether the continuity & tightness of earth conductor are checked?		
3	Mention the SWG of earth conductor used		
4	Mention the value of Earth Resistance		
	<b>ELECTRICALLY OPERATED MACHINES / ACCESSORIES</b>		
1	Whether the plug top provided for all electrical connections?		
2	Are all metal parts of electrical equipment's & light fittings / accessories grounded?		
3	Is there any shed / cover for welding machines?		
4	Are light fittings fixed at proper places?		
5	Are Portable power tools maintained as per norms?		
6	Any other Information		



## 6.0 VEHICLE & EARTH MOVING EQUIPMENT INSPECTION CHECKLIST

Name of Project: \_\_\_\_\_ Make / Model \_\_\_\_\_ :  
Job No. \_\_\_\_\_ : Asset code (If applicable) \_\_\_\_\_ :  
Inspected By \_\_\_\_\_ : Owned by \_\_\_\_\_ :  
Date \_\_\_\_\_ :

<b>Sl. No.</b>	<b>Points</b>	<b>Observation</b>	<b>Measures</b>
1	Engine condition		
2	Clutch / brake / Hand brake		
3	Hydraulic System		
4	Guards / Covers / Doors		
5	Fastener lock pins / Keys.		
6	Horn / Reverse horn / Lights		
7	Indicators / Wiper Blades		
8	Operator's fitness		
9	Tyre pressure / Tyre Condition		
10	Condition of Battery and Lamps		
11	Operating levers / steering		
12	Gauges & warning devices		
13	Fire extinguisher provided		
14	Rear Side Mirror		
15	Seat Belt		
16	Triangular Retro Reflectors – 4 nos. (Front side – 02, Rear side – 02)		
17	Chock blocks (min 02 nos.)		
18	Delay Start Mechanism (for rollers)		

## 7.0 DIESEL GENERATOR (DG) INSPECTION CHECKLIST

Name of Project :

Job No. :

Asset Code :

Inspected By :

Date :

Sl. No.	Points	Observations	Measures
1	Whether the continuity and tightness of earth conductor are checked?		
2	Mention the SWG of the earth conductor used		
3	Whether earth resistance is measured?		
4	Mention the value of Earth Resistance		
5	Is DG provided under shed / cover?		
6	Whether entry is restricted into the DG room?		
7	Are cable trenches are covered?		
8	Is insulation provided on the battery terminals?		
9	Is thermal insulation done for the DG exhaust?		
10	Whether stack height is maintained as per PCB regulations?		
11	Whether DG exhaust is diverted outside the shed?		
12	Are all the rotating parts (coupling, radiator fan) of DG guarded?		
13	Whether any leakage of fuel / oil in the DG room?		
14	Whether DG surrounding is free from flammable material?		
15	Whether fire extinguisher / fire buckets with stand are provided?		
16	Whether DG is fitted with Acoustics & Silencer insulations?		

## 8.0 CRANE INSPECTION CHECKLIST

Name of Project :

Job No. :

Inspected By :

Date :

Sl. No.	Points	Observation	Measures
1	<b>Hook and Hook Latch</b>		
2	Over-Hoist Limit Switch		
3	Boom-Limit Switch		
4	Boom Angle indicator		
5	Boom-Limit cut-off switch		
6	Over load limit switch		
7	Condition of boom		
8	Condition of Ropes		
9	No. of load lines		
10	Size and condition of the sling		
11	Stability of crane		
12	Soil Condition		
13	Swing Brake & Lock		
14	Propel Brake & Lock		
15	Hoist Brake & Lock		
16	Boom Brake & Lock		
17	Swing Alarm		
18	Main clutch		
19	Leakage in hydraulic cylinders		
20	Out riggers fully extendible		
21	Tyre pressure		

<b>Sl. No.</b>	<b>Points</b>	<b>Observation</b>	<b>Measures</b>
22	Condition of Battery and Lamps		
23	Guards of moving and rotating parts		
24	Load chart provided		
25	Numbers, position and size of pendant ropes		
26	Reverse horn & Rear view mirror		
27	Validity of Certification by competent authority		
28	Operator's Fitness		
29	Fire Extinguisher in operator's cabin		
30	Caution Boards		

## 9.0 TOWER CRANE INSPECTION CHECKLIST

Name of Project: \_\_\_\_\_ Job No. : \_\_\_\_\_  
Inspected By : \_\_\_\_\_ Date : \_\_\_\_\_  
Make & Model : \_\_\_\_\_ Asset Code : \_\_\_\_\_  
Height : \_\_\_\_\_ Jib Length : \_\_\_\_\_

SI No	Description	Observation	Measures
<b>I</b>	<b>Foundation - Stability</b>		
<b>II</b>	<b>Mast section</b>		
1.	Check the Mast & Fasteners		
2.	Check the climbing ladder mountings and platforms		
3.	Check the tie-collar mounting and Pins		
4.	Check the climbing gauge mounting pins		
5.	Load Chart Displayed on crane mast		
6.	Check on the mast anchorages		
7.	Is the lightening arrestor available		
<b>III</b>	<b>Swing Unit</b>		
1.	Check on the Cat Head		
2.	Check the revolving bolts for tightness		
3.	Check the Cabin Mounting Pin and Collar pins		
4.	Check the counter jib tie & main Jib tie Connecting Pins		
5.	Check the Swing Brake, Limit switch & Alarm		
6.	Operator Visibility & Wind screen		
7.	Is the Anemometer functional		
8.	Is the aviation lamp functional (Reqd. for 30mt & above)		
9.	Fire Extinguisher installed at operators cabin & G.L		

10.	Emergency Stop button is functional		
<b>IV</b>	<b>Counter Jib</b>		
1.	Check the Counter Jib Mounting Pins and Cotter Pins		
2.	Check the Platform mounting pins, handrail etc		
3.	Check the counter weight placement and pins		
4.	Check the mounting of the hoist winches		
5.	Check the Pins and cotter pins of the Tie Rod		
6.	Structural stability of platform & counter weight		
<b>V</b>	<b>Main Jib</b>		
1.	Check the Mounting Pins and Cotter Pins		
2.	Check the Tie rod pins and cotter pins.		
3.	Check Jib Inserts connecting pins and cotter pins		
4.	Check the light fitting mounting for tightness		
5.	SWL displayed on main jib for various operating radius		
<b>VI</b>	<b>Hoist</b>		
1.	Check the condition of wire rope		
2.	Check over hoist limit switch		
3.	Check the brake pads for excessive wear		
4.	Check the rope swivel for free rotation		
5.	Check the Moment Cut off Limit Switch		
6.	Check the brake Cylinder for proper function & leakage		
<b>VIII</b>	<b>Trolley</b>		
1.	Check the Trolley rope, brake and lock arrangement		
2.	Check the working platform, extreme end limit switches		



## 10.0 GANTRY CRANE INSPECTION CHECKLIST

Name of Project :

Job No. :

Inspected By :

Date :

Sl. No.	Points	Observation	Measures
1	<b>Condition of rail</b>		
2	Hooter / Alarm for long travel motion		
3	Over hoist Limit switch		
4	Limit switches for Long travel		
5	Limit switches for Cross travel		
6	Hook & Hook Latch		
7	Condition of Ropes		
8	Condition of brake liners & brake drums		
9	Mechanical stoppers on both ends of rail		
10	Stoppers arrangement for gantry (while not in use)		
11	Routing of power cables		
12	Rain protection for drive motors & DBs		
13	Emergency power shut-off device		
14	Aviation Lamp		
15	Load Test details		
16	SWL Display		
17	Validity of Certification by competent authority		
18	Cage arrangement for vertical ladders		
19	Work platform, handrails and toe boards		
20	Housekeeping		
21	Operator's Fitness		
22	Caution Boards		

## 11.0 PLANT INSPECTION CHECKLIST

Name of Project:

Job No. :

Inspected By :

Date :

<b>Sl. No</b>	<b>Points</b>	<b>Observation</b>	<b>Measures</b>
1	<b>Plant boundary are demarcated to avoid hazards arising out of unintended operations</b>		
2	<b>Plant supports are as per the design drawing</b>		
3	<b>Demarcation of working area, vehicular movements</b>		
4	<b>All rotating parts are adequately guarded</b>		
5	<b>Emergency stoppers for moving conveyers &amp; plant are provided at accessible areas</b>		
6	<b>Doors of the moving parts are interlocked to avoid unauthorized operation during plant running</b>		
7	<b>Adequate accesses are provided to reach all working locations.</b>		
8	<b>Delay start mechanism is installed with hooters / siren</b>		
9	<b>Safety of the Loading ramps</b>		
10	<b>Protection against entrapping of peoples in the loading hoppers</b>		

<b>Sl. No</b>	<b>Points</b>	<b>Observation</b>	<b>Measures</b>
11	<b>Illumination adequate</b>		
12	<b>Earthing provided</b>		
13	<b>Environment Protection measures implemented</b>		
14	<b>Lightning arrestors are provided</b>		
15	<b>Daily check procedure is followed</b>		
16	<b>Operator Fitness</b>		
17	<b>LOTO system implemented</b>		
18	<b>Effective functioning of pressure relief arrangement in silos.</b>		
19	<b>Maintenance permit system is followed regularly</b>		
20	<b>Fire Protection &amp; Fire Fighting arrangement are adequate</b>		

Note: This checklist shall be used for Batching Plant, Crushers, Hot Mix plants etc. Additional checklist points shall be developed at project level on need basis.